

Safety Performance and Robustness of Heavy Vehicle AVCS

Principal Investigator:

J. Christian Gerdes

**Department of Mechanical Engineering - Design Division
Stanford University**

Co-Investigators:

Paul Yih

Krishna Satyan

**Department of Mechanical Engineering - Design Division
Stanford University**

California PATH Program

Year One Report for MOU 390

January 2002

Abstract

Commercial heavy vehicle research at the California Partners for Advanced Transit and Highways (PATH) program has focused on the development of controllers for partially to fully automated driving environments. Safe performance of Advanced Vehicle Control Systems (AVCS) must be demonstrated for a wide range of operating conditions and truck configurations to avoid any one of the many failure modes—such as rollover or jackknifing—common to articulated heavy vehicles. For this purpose, a multi-body dynamic model of a tractor semitrailer has been developed using a commercially available dynamic analysis software program. Model parameters are based on a survey of heavy truck literature; the report discusses different types of component configurations and, in addition, provides numerical ranges for important physical parameters. Several safety performance measures along with associated maneuvers are proposed as a test to quantify overall safety of the controlled vehicle.

keywords: commercial heavy vehicles, advanced vehicle control systems, multi-body dynamic model, safety performance measures, physical parameters

Table of contents

Executive summary.....	4
1 Introduction.....	5
2 Parameters that affect truck safety.....	6
2.1 Tires	6
2.2 Suspension	8
2.3 Steering.....	10
2.4 Configuration	13
3 Methods for evaluating truck safety	14
3.1 Performance measures	14
3.2 Test maneuvers	16
3.2.1 Maneuvers and associated performance measures listed in [15].....	16
3.2.2 Maneuvers and associated performance measures listed in [2].....	16
3.2.3 Maneuvers and associated performance measures listed in [8].....	17
4 The ADAMS truck model.....	18
4.1 Model description	18
4.2 Experimental verification.....	22
5 Conclusion and Future Work.....	24
6 Acknowledgements.....	25
7 References.....	25
8 Appendices.....	27
8.1 California vehicle code	27
8.1.1 Provisions on vehicle width.....	27
8.1.2 Provisions on vehicle height.....	28
8.1.3 Provisions on vehicle length.....	28
8.1.4 Provisions on vehicle weight.....	31
8.2 References for parameters and performance measures.....	38
8.2.1 Reference details by date	38
8.2.2 References by parameter or performance measure.....	59
8.3 PATH experimental heavy vehicle	64
8.3.1 Steering system dimensions top view (millimeters).....	64
8.3.2 Steering system dimensions side view (millimeters).....	65
8.3.3 Front suspension dimensions side view (millimeters).....	66
8.3.4 Rear suspension dimensions side view (millimeters).....	67
8.3.5 Trailer suspension dimensions side view (millimeters).....	68
8.3.6 Track rod dimensions rear view (millimeters).....	69
8.3.7 Tractor dimensions (millimeters).....	70
8.3.8 Semitrailer dimensions (millimeters).....	71
8.3.9 Weights and moments of inertia from [16].....	72
8.3.10 Suspension parameters from [16]	72

Executive summary

Safety is of paramount importance in any proposed system for control or automation of heavy trucks. In contrast to passenger cars, heavy trucks are more complicated systems with a variety of possible failure modes including rollover, jackknifing and trailer swing. Any control system developed for a heavy truck should, therefore, be demonstrated to avoid these modes. Similarly, it makes sense to compare control algorithms for heavy trucks in terms of safety. Yet the question remains how to define performance metrics suitable for capturing safety for heavy truck control and what level of modeling detail is required for evaluating safety.

Most work in heavy truck control has been based around fairly simple dynamic models. This is a natural result of the need for simplicity in models used for automatic control. Yet these models obscure some of the basic behaviors of the vehicle – such as roll and dynamic lateral weight transfer – that fundamentally impact safety. This raises the question whether a particular controller that demonstrates reduced tracking error in a lanekeeping setting could in fact achieve this performance at the expense of roll stability. Such concerns cannot be addressed without a more detailed, design-oriented model of a heavy truck with which to simulate control algorithms. This project focused on the development of such a model for the current PATH research truck and the related issues of parameterization and selection of safety metrics.

The report is structured as follows. In the first section of this report we have listed the major physical parameters that influence heavy truck safety performance. The question that remains to be answered, then, is how does one quantify truck safety? In the second section we have compiled a list of safety performance measures developed by researchers to evaluate truck safety. These measures will aid in the design of heavy vehicles by ensuring that they meet “safe performance” criteria. Based on previous work in the truck size and weight community, we recommend that evaluation of rearward amplification, high-speed transient offtracking, and dynamic load transfer ratio for the *SAE* standard lane change maneuver be used for evaluating safety for automated heavy trucks. In the third section, we describe a multi-body dynamic model for a heavy truck. The model will be used for future work in which we look at how the performance measures might be applied to the design of a heavy vehicle steering control system. Finally, a large annotated bibliography of papers related to heavy vehicle parameters and safety metrics developed over the course of this project is attached as an appendix.

1 Introduction

Roughly 70 percent of the total value of domestic freight in the United States is carried exclusively by truck. By any measure—weight, value, or distance—more freight is transported over the nation’s roads and highways than on rails, over water, or through the air. According to the U.S. Department of Commerce, from 1993 to 1997, the amount of goods shipped by truck increased 25% (*1997 Commodity Flow Survey*). The downside to a growing dependence on road freight is that large trucks are involved in almost twice as many fatal crashes per mile traveled when compared to passenger vehicles (*Large Truck Crash Facts 1999*, Federal Motor Carrier Safety Administration). Although truck safety has steadily improved over the years, the challenge for the trucking industry and transportation regulators is to further reduce the number of truck related crashes even as truck traffic continues to increase.

Traditionally, heavy vehicles have been regulated by strictly defined weight and dimension limits. Weight limits were set in place primarily to protect the infrastructure of roads and bridges from excessive wear and damage, while dimensional limits ensure that a vehicle fits within the width of the road and has sufficient overhead clearance when traveling under bridges or through tunnels. Neither of these types of rules, however, directly addresses safe driving performance—for example, how well a vehicle turns, stops, or stays within lanes. A new idea being discussed in both government and industry is to establish heavy truck standards based on a set of performance measures derived from dynamic methods of analysis. Each standard defines a numerical limit beyond which the performance is unacceptable. These standards would complement or even supersede the current rules, which apply to all trucks regardless of how safely they perform. The advantage of performance-based standards is that it allows both truck manufacturers and operators more flexibility and opportunity for innovation in their continuing efforts to improve safety while boosting productivity and lowering costs. At the same time, performance-based standards will penalize those vehicles that meet the existing rules but are unsafe due to poor design.

A significant body of literature exists in the area of heavy vehicle safety performance. An initial goal of this project is to undertake a thorough study of performance measures used by researchers to evaluate heavy truck safety and to organize from these measures a representative set that encompasses the whole spectrum of safe driving performance. As an aid to researchers, the initial literature study will also include a compilation of typical numerical values or ranges of values for physical parameters—such as tire properties and suspension characteristics—which affect safety performance. The subsequent goal is to begin looking at ways in which safety performance can be improved using the performance standards as a basis for evaluation. For this purpose, a dynamic model of a tractor-semitrailer (similar in dimension to the PATH experimental heavy truck) is developed with the *ADAMS* dynamic simulation and analysis program. The model will be validated against experimental data obtained from testing of the PATH vehicle.

2 Parameters that affect truck safety

2.1 Tires

Tires are perhaps the most important, but difficult to model, component of a heavy truck. In addition to supporting the vehicle and damping road irregularities, the tires provide the longitudinal and lateral forces necessary to change the speed and direction of the vehicle. These forces are produced by the deformation of the tire where it contacts the road during acceleration, braking, and cornering.

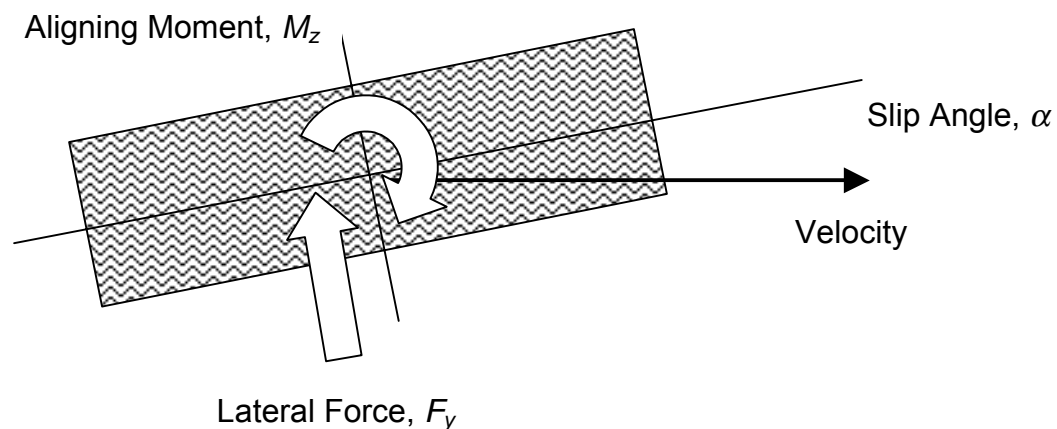

Figure 1: Tire operating at a slip angle.

In the absence of side forces, a rolling tire travels straight ahead along the wheel plane. During a cornering maneuver, however, the tire contact patch “slips” laterally while rolling such that its motion is no longer in the direction of the wheel plane (Figure 1). The angle between its direction of motion and the wheel plane is referred to as the slip angle, α . This lateral “slip” generates a lateral force, F_y , at the tire-ground interface. Because the force acts slightly behind the center of the wheel, it produces an aligning moment, M_z , which tends to realign the wheel in the direction of rolling.

Normal cornering maneuvers result in small slip angles, low lateral force, and minimal sliding of the tire. At larger slip angles lateral force increases and reaches a maximum as the tire begins to slide. Figure 2 illustrates the relationship between lateral force and slip angle for a typical tire. For small values of α —say, less than four degrees—the relationship is nearly linear. The initial slope of the curve is known as the cornering stiffness, C_α , described in units of force per degree.

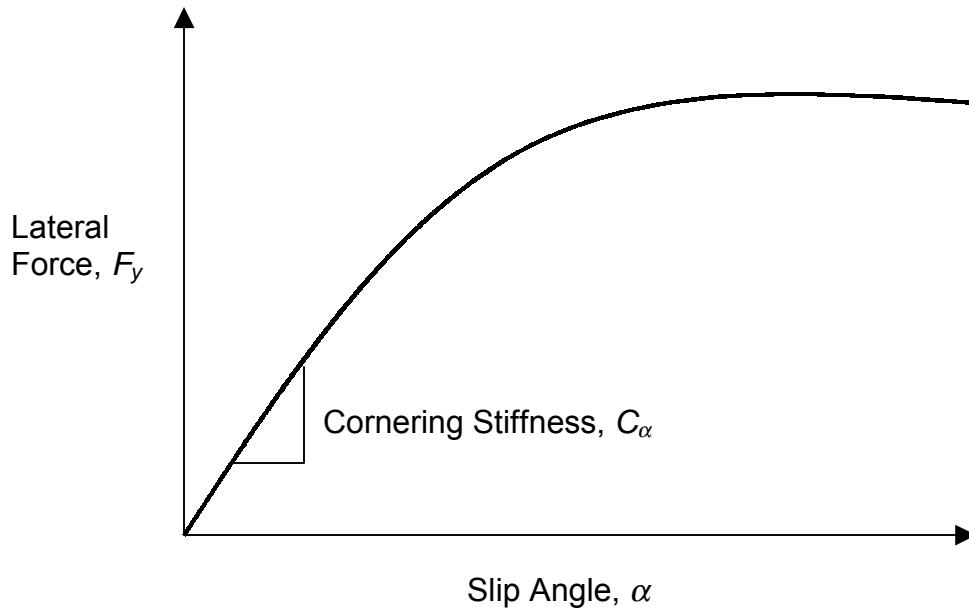

Figure 2: Lateral force vs. slip angle.

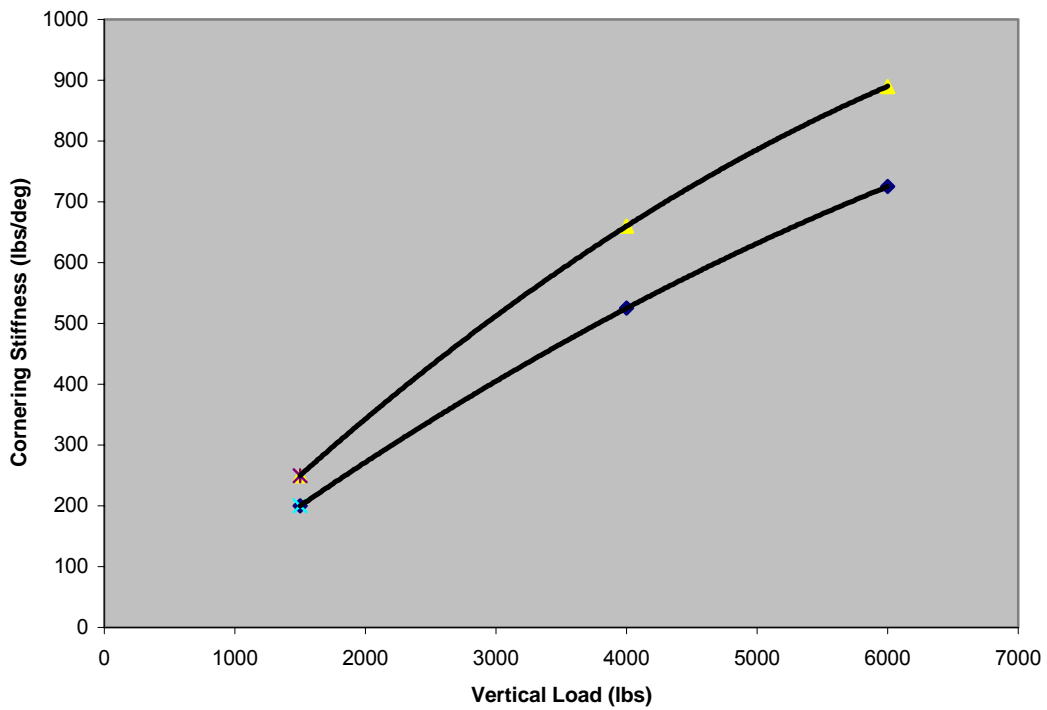

Figure 3: Cornering stiffness vs. vertical load for radial tires [6].

The cornering stiffness property, often used to evaluate and compare tire cornering behavior, depends on many design and operational factors, but it is most influenced by vertical load on the tire. Figure 3 shows the range of variation in cornering stiffness due to vertical load for typical truck radial tires.

Several nonlinear tire models have been developed to describe the nonlinear behavior of tires at large slip angles. Two of the more commonly used nonlinear models are the Pacejka tire formula and the Combinator tire model. The Pacejka tire formula relates lateral force to slip angle: $F_y(\alpha) = D \sin\{C \operatorname{atan}[B\alpha - E(B\alpha - \operatorname{atan}(B\alpha))]\}$. A sample set of constants for a particular tractor-trailer combination is listed in Figure 4.

	B	C	D	E
Tractor Front Axle	3.10	1.40	0.75	0.85
Tractor Rear Axle	7.10	0.65	1.45	0.91
Trailer Axle	7.50	1.30	0.77	0.26

Figure 4: Pacejka tire formula constants [13].

The Combinator tire model similarly expresses the lateral force in terms of slip angle: $F_y(\alpha) = S_y + D \sin\{C \arctan[B(\alpha - S_x)(1 - E) + E \arctan(B)(\alpha - S_x)]\}$ where $C = S_y/(BD)$. Furthermore, each of the parameters D , S_x , S_y , S_t , B , and E is expressed in terms of the vertical load F_z : $[Parameter] = C_0 + C_1 F_z + C_2 F_z^2 + C_3 F_z^3$. Figure 5 lists the constant terms C_0 through C_3 used to calculate each parameter for a given vertical load.

Constants	Parameters					
	D	S_x	S_y	S_t	B	E
C_0	4.28E+02	1.89E-01	6.12E+01	1.20E+02	6.42E-02	4.92E-01
C_1	-8.95E-01	2.41E-05	-3.16E-02	1.61E-01	-2.14E-06	-1.79E-05
C_2	-8.37E-06	6.61E-10	-2.19E-07	1.66E-06	-4.40E-11	-1.03E-09
C_3	-5.45E-11	4.58E-15	7.06E-13	4.37E-12	-2.31E-16	-1.28E-14

Figure 5: Combinator tire model constants [12].

2.2 Suspension

The suspension plays an important role in heavy truck handling through its effect on body roll and dynamic loading on the tires. As mentioned in the previous section, the vertical load on the tire has a primary influence on cornering stiffness, which in turn determines the lateral force that can be generated during cornering. Compliance in the suspension causes the center of gravity of the body to roll outward in a turn relative to the axle, transferring load to the outside tires. The point about which the body rolls about the axle is known as the roll center.

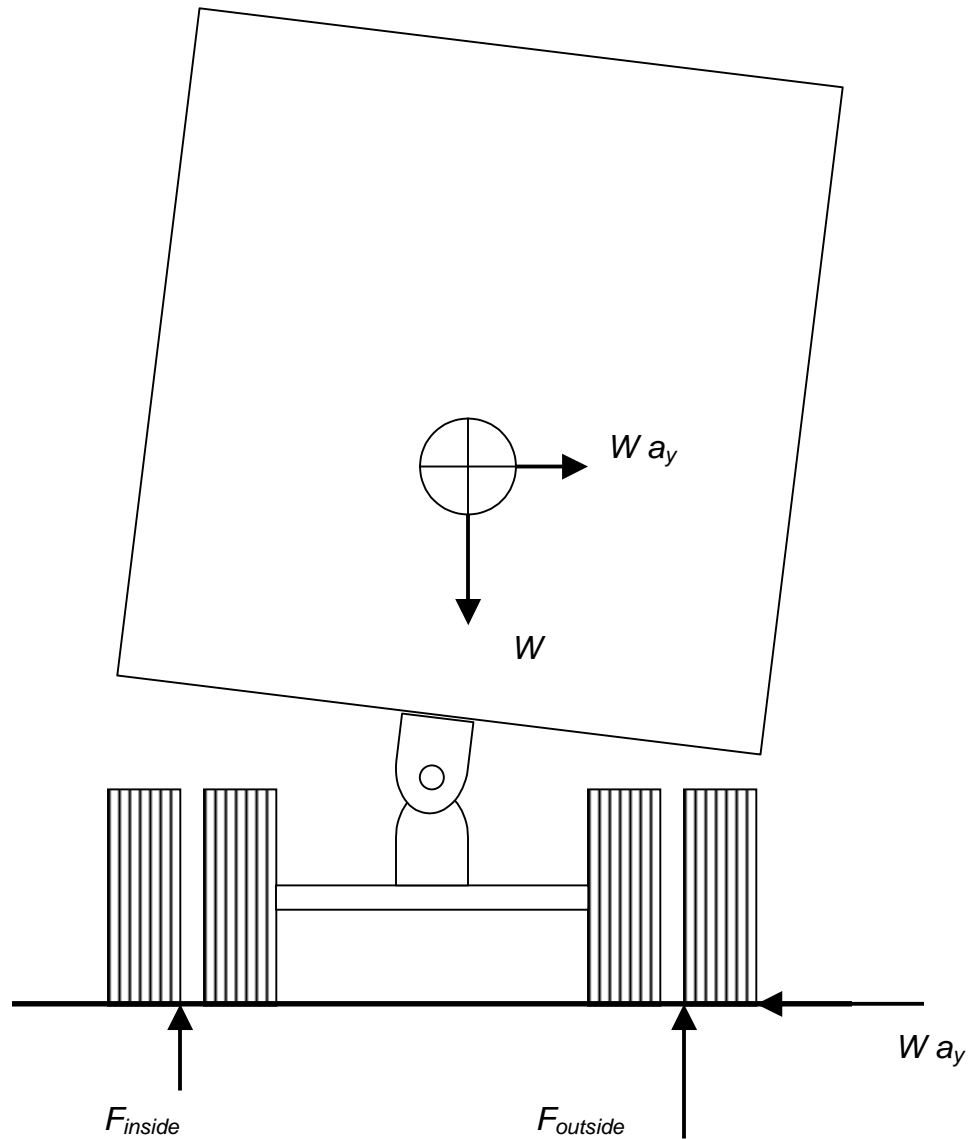

Figure 6: Heavy truck in a turn.

Although heavy truck suspensions come in a variety of shapes and sizes, their effect on handling performance can be characterized by several key properties: roll center height, roll stiffness, and lateral stiffness. Roll stiffness is the torsional stiffness of the suspension measured about the roll center. The composite roll stiffness of a suspension is determined by the stiffness of the springs, the spacing of the springs, and any auxiliary roll stiffness. Lateral stiffness corresponds to lateral deflection at the roll center due to compliance in the suspension linkages and bushings. The following tables list typical values for different suspension types and axle location.

Suspension Type	Single	Drive	Trailer
Single, leaf	1.0-4.5 (2.5)	3.3-11.2 (7.0)	7.4-10.5 (9.0)
Trailing-arm, air		2.2-20.1 (11.0)	6.8-20.1 (14.0)
Four-spring		5.0-14.0 (7.0)	7.5-17.2 (12.5)
Two-spring		4.8-12 (8.5)	
Walking-beam	3.0-6.3 (5.0)	3.8-17.9 (9.0)	4.9-9.1(7.0)
Other		6.4-8.5 (7.5)	

Figure 7: Roll stiffness range and typical value (kNm/deg) [17].

Suspension Type	Single	Drive	Trailer
Single, leaf	340-625 (500)	540-825 (700)	625-750 (700)
Trailing-arm, air		340-860 (550)	75-650 (400)
Four-spring		570-800 (675)	575-810 (700)
Two-spring		320-890 (700)	
Walking-beam			560-875 (775)
Other		625-650 (650)	

Figure 8: Roll center height range and typical value (mm) [17].

Suspension Type	Single	Drive	Trailer
Single, leaf	1.5-2.6 (2.1)	1.5-7.7 (6.0)	4.25-5.9 (5.1)
Trailing-arm, air			0.65-5.4 (3.0)
Four-spring		4.15-4.4 (4.2)	1.9-5.1 (4.0)
Two-spring		2.5-4.4 (3.8)	
Walking-beam			
Other		0.4-0.7 (0.5)	

Figure 9: Lateral stiffness range and typical value (kN/mm) [17].

2.3 Steering

The geometry of a wheel with respect to the suspension and vehicle body in the static condition can be described by the wheel's toe angle, camber angle, caster angle, and tandem skew angle. These parameters significantly affect the steering characteristics of a vehicle.

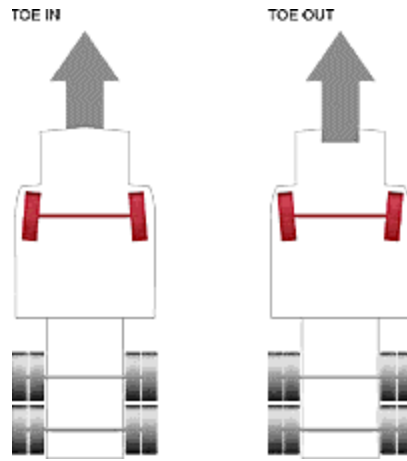

Figure 10: Toe.

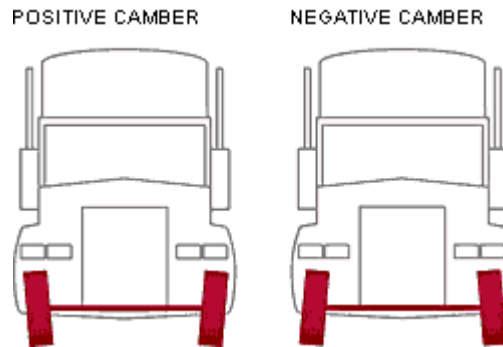

Figure 11: Camber.

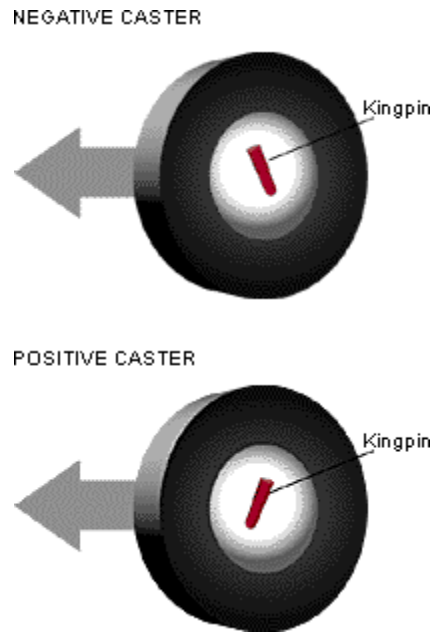

Figure 12: Caster.

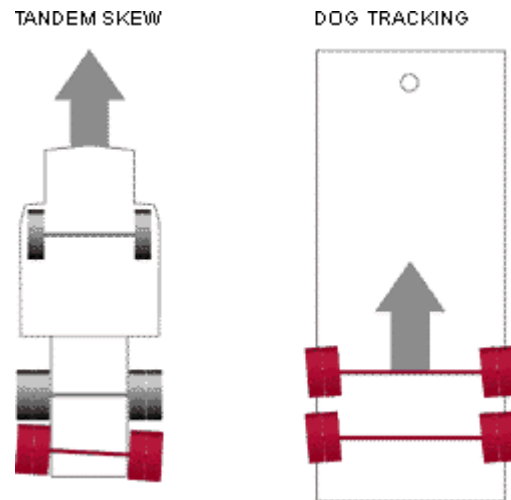

Figure 13: Tandem skew and dog tracking.

The following table lists typical specifications and a range of values measured from a sample of actual vehicles.

	Specification	Sample Ranges
Toe	0-0.1 degrees	0-0.22 degrees
Camber	+/- 0.44 degrees	+/- 0.53 degrees
Caster	+/- 1.25 degrees	+/- 1.65 degrees
Tandem Skew	+/- 0.1 degrees	+/- 0.17 degrees

Figure 14: Steering geometry [14].

2.4 Configuration

The difficulty in predicting truck safety performance lies in the fact that there are such a wide variety of truck configurations in terms of wheelbase, number of axles, and suspension type. In addition, the weight and center of gravity vary drastically depending on the load that the truck is carrying. All of these factors significantly affect safety performance. Commercial vehicle size and weight limits from the California Vehicle Code [3] are listed below in order to provide some guidelines to use for safety evaluation. The maximum weight, height, and length limits generally describe a worst-case scenario when it comes to truck safety. This is not always the case however. Often, truck suspensions and braking systems are designed to operate at their optimum level when the vehicle is fully loaded. Under lightly loaded or unloaded conditions, a vehicle may perform worse than when fully loaded.

The following excerpts from the California Vehicle Code summarize vehicle size, weight, and load regulations for vehicles (including heavy commercial vehicles) operated in the state of California. The appendices contain a more complete version of the California Vehicle Code sections pertaining to vehicle width, height, length, and weight.

The maximum length for a single vehicle is 40 feet. A combination of a truck tractor and trailer coupled together shall not exceed a total length of 65 feet. A combination of vehicles consisting of a truck tractor, a semitrailer, and a trailer cannot be longer than 75 feet, providing the length of either trailer does not exceed 28 feet 6 inches. The load length on any vehicle or combination of vehicles may not be more than 75 feet long measured from front of vehicle or load to back of vehicle or load.

The outside width of the body of the vehicle or the load thereon must not exceed 102 inches (8 ½ feet). The width of a vehicle with pneumatic (air filled) tires, measured from the outside of one wheel to the outside of the opposite wheel, must not exceed 108 inches (9 feet).

The height limit, measured from the surface on which the vehicle stands, is 14 feet. Vehicle load height, measured from the surface on which the vehicle stands may not exceed 14 feet.

The gross weight which can be carried by the wheels of any one axle must not exceed 20,000 pounds (20,500 pounds for buses). Additionally, the load limit state by the tire manufacturer (molded on at least one sidewall) shall not be exceeded. The weight carried by the wheel or wheels on one end of an axle must not exceed 10,500 pounds.

Combinations of vehicles made up of a trailer or semitrailer, and each vehicle in combination, must meet either the weight provisions of VC 35551 or the following:

The gross weight placed on a highway by the wheels on any one axle of a vehicle must not exceed 18,000 pounds. The gross weight on any one wheel, or wheels, supporting one end of an axle and resting on a roadway must not exceed 9,500 pounds. Exceptions: The gross weight placed on a highway by the wheels on any front steering axle of a motor vehicle must no exceed 12,500 pounds.

The total gross weight, with load, placed on a highway by any two or more consecutive axles of a combination of vehicles, or a vehicle in the combination, where the distance between the first and last axles of the two or more consecutive axles is 18 feet or else, must not exceed that given for the respective distance as shown in the table in VC 35551.5. When the distance between the first and last axles is more than 18 feet, use the table shown in VC 35551.5.

3 Methods for evaluating truck safety

3.1 Performance measures

Safety performance is undisputedly one of the most important issues in the design and control of heavy trucks. Advanced Vehicle Control Systems (AVCS)—in the form of either driver assistance systems or full automation—hold considerable promise for increased heavy vehicle safety. Unfortunately, the complexity of truck dynamics makes it difficult to establish exactly what constitutes a safe truck, and the subsequent ambiguity in defining safe performance makes it difficult to determine the benefits of implementing advanced control systems on heavy trucks. To convince the public and wary policymakers of the safety benefits and performance guarantees of such systems, an appropriate method for quantifying heavy vehicle safety is needed.

Consequently, a primary goal of this project is to research common heavy truck safety performance measures applicable to heavy truck manufacturers and AVCS researchers. This framework of performance measures should successfully cover the range of competing safety demands (such as yaw stability, rollover avoidance and stopping distance) faced by heavy trucks. The performance measures listed below can be used in the analysis of heavy truck safety for current and future truck designs. In addition, although these performance measures do not specifically mention active control systems, they do provide a starting point for quantifying the intrinsic safety benefits of active systems in a performance-based context. Such measures could be used to evaluate and differentiate between later control designs, or benchmark the controller's performance relative to a human driver. Many of these measures originate in two University of Michigan Transportation Research Institute (UMTRI) reports [5] & [7].

- **Braking efficiency** – the fraction of the available tire-road friction that can be used without locking any wheels
- **Braking stability** – a measure of the directional stability of a vehicle under combined braking and turning
- **Dynamic load-transfer ratio** – the fractional change in load between left and right side tires in an evasive maneuver
- **Effective overhang ratio** – the distance from the turn center to the rear of the trailer divided by the trailer wheelbase
- **Friction demand** – the tire-pavement friction necessary for a truck to turn without jackknifing
- **Friction utilization** – the ratio of braking force to vertical load at each axle
- **High-speed steady state offtracking** – the lateral offset between the path of the first axle and the path of the last axle in a steady turn
- **High-speed transient offtracking** – the lateral overshoot of the last axle with respect to the path of the first axle in an evasive maneuver
- **Low-speed transient offtracking** – the lateral offset between the path of the first axle and the path of the last axle in a right angle turn
- **Rearward amplification** – the ratio of the highest lateral acceleration of the last trailer to the highest lateral acceleration of the tractor during evasive maneuver (primarily of concern for multi-trailer units)
- **Static rollover threshold** – the lateral acceleration at which the truck rolls over in a steady turn

- **Understeer coefficient** – a measure of how aggressively a truck responds to a steering input at a given lateral acceleration
- **Yaw damping ratio** – a measure of the attenuation in trailer oscillation initiated by a steering input

3.2 Test maneuvers

Since trucks possess multiple failure modes, numerous test maneuvers have been developed by researchers in the past to evaluate a multitude of performance measures. Some of the more common test maneuvers used in industry and research—and the performance measures associated with these maneuvers—are listed below with suggested baseline values for some measures.

3.2.1 Maneuvers and associated performance measures listed in [15]

RTAC-a maneuver (constant radius J-turn followed by tightening spiral turn at 100 kph)

- High-speed steady state offtracking
- Static rollover threshold

RTAC-b maneuver (lane-change evasive maneuver at 100 kph)

- Rearward amplification
- High-speed transient offtracking
- Dynamic load transfer ratio

RTAC-c maneuver (8 kph right-angle turn of radius 9.8 m)

- Low-speed transient offtracking

Pulse-steer maneuver (0.1 degree of front wheel steer angle for 0.2 seconds at 100 kph)

- Yaw damping ratio

3.2.2 Maneuvers and associated performance measures listed in [2]

Steady turn at 100 kph

- Static roll threshold (tractor lateral acceleration should exceed 0.4 g before rollover)
- High-speed offtracking (lateral offset between path of tractor steer axle and last axle should not exceed 0.46 m)
- Understeer coefficient

Evasive maneuver at 100 kph

- Load transfer ratio (fractional change in load between left and right side tires should not exceed 0.6)
- Transient high-speed offtracking (lateral overshoot of rear axle should not exceed 0.8 m)

90-degree turn of radius 14 m at 8.8 kph

- Friction demand (tire-pavement friction needed to prevent jackknifing should not exceed 0.1)
- Low-speed offtracking (comparable to 4.8 m wheelbase tractor with 12.5 m wheelbase semi-trailer)
- Effective overhang ratio (distance from turn center to rear of trailer divided by semi-trailer wheelbase should not exceed 0.35)

3.2.3 Maneuvers and associated performance measures listed in [8]

90-degree turn of radius 45 ft (13.7 m) at low speed

- Low-speed offtracking (path of last axle no more than 17 ft (5.2 m) inside path of front axle)
- Friction demand (jackknifing will not occur when coefficient of friction is above 0.2)

Steady turn of radius 1200 ft (365 m) at 55 mph (88.5 kph)

- High-speed offtracking (path of last axle no more than 1 ft (0.3 m) outside path of front axle)

Constant deceleration braking

- braking efficiency (at least 0.7 of available tire-road friction used without locking any wheels)
- friction utilization
- stopping distance

Steady turn at high speed

- rollover threshold (achieve 0.38 g lateral acceleration without rolling over)

Obstacle avoidance (50 mph (80 kph) lane change maneuver)

- Rearward amplification (less than 2.0 in (5.08 cm) for worst case maneuver)

Braking during turning (a steady turn of radius 1500 ft (455 m) at 50 mph (80 kph) with a 0.8 second pulse of heavy brake application)

- Braking stability

4 The *ADAMS* truck model

4.1 Model description

A good dynamic model is an essential tool for assessing the performance characteristics of a vehicle. The difficulty in creating the model comes from determining the appropriate level of detail that will accurately represent the dynamics of interest. Too much detail, and analysis becomes unnecessarily complicated. With too little detail, the model fails to sufficiently resemble the real system. As an example, the commonly used four-degree of freedom truck model—the degrees being lateral position, longitudinal position, yaw angle, and trailer articulation angle—while useful for many types of analyses, lacks information about roll angle. During normal driving, roll dynamics can be safely neglected for cars, but for a truck, especially if it is heavily loaded, even a mild turning maneuver may place it in danger of rolling over completely. In addition, due to the particular kinematics of truck suspensions, body roll produces an additional steering effect known as roll steer. By using a somewhat more complicated representation than the four-degree of freedom model—one that includes suspension kinematics—we have attempted to capture dynamics critical to safety performance that would otherwise be lost.

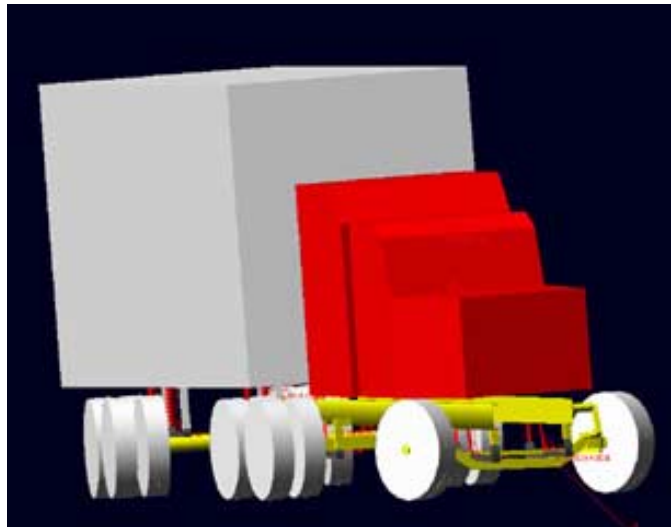

Figure 15: *ADAMS* model of heavy truck.

For the modeling environment, we chose the *Automatic Dynamic Analysis of Mechanical Systems (ADAMS)* computer software package distributed by Mechanical Dynamics, Inc. *ADAMS* is widely used in the automotive industry for simulating full vehicle dynamics. An image of the complete *ADAMS* heavy truck model is seen above in Figure 15. We based the physical parameters of our model on the PATH experimental heavy vehicle, a

1992 Freightliner FLD 120 Class 8 tractor with 45-foot semitrailer (Figure 16). Major dimensions, such as the track width, axle spacing, and suspension component lengths were obtained from the actual vehicle and are listed in the appendices. Mechanical parameters such as mass, moment of inertia, suspension stiffness and damping were estimated from data found in [11] and [16] (see appendices).



Figure 16: PATH experimental heavy vehicle.

The model shown in Figure 15 is composed of rigid-body components attached to each other via joints, springs, and dampers. The chassis and cab are treated as a single body. Figure 17 depicts the front suspension of the real vehicle. The front axle is suspended by leaf springs directly attached to the frame. Hydraulic shock absorbers provide damping. While a leaf spring derives its characteristics from deformation of the leaves and friction between the leaves, this type of behavior is difficult to model. We have instead substituted the leaf spring with a rigid link attached to the frame at its forward end via a revolute joint and at the other end by a spring (Figure 19). The result of this representation is that as the suspension deflects, the motion of the axle traces an arc similar to that of the axle on the actual vehicle. The spring constants in the model will approximate the roll stiffness and vertical stiffness provided by the leaf springs. The location of the dampers in the model is physically identical to the real vehicle, but the damping values must account for the additional damping provided by the real leaf springs.

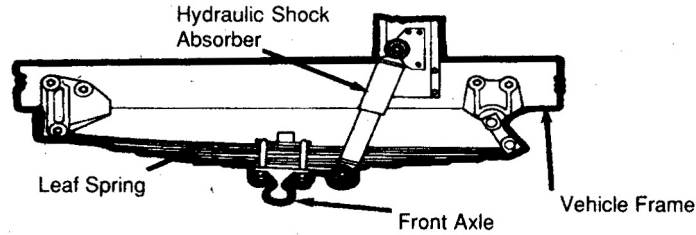

Figure 17: Front suspension.

One problem encountered in the model was that fixing the axle to the leaf springs at either end did not permit the body to roll relative to the axles. To provide the necessary compliance, we placed bushings at these junctures. The bushings are stiff in the longitudinal directions to maintain the correct axle location with respect to the frame, but they are soft in the rotational directions to allow the axle to twist relative to the frame.

The front wheels are steered by the rotation of the pitman arm, which transmits a force through the drag link to the left wheel assembly, and the steering action is duplicated at the right wheel through the tie rod (Figure 18) with an approximate Ackerman steering geometry. In the model, the pitman arm rotates with respect to the truck frame via a revolute joint (Figure 19). The rest of the linkages—the drag link, left and right spindles, and tie rod—connect to each other via spherical joints. For cost and durability reasons, these connections are normally designed and built as revolute joints with bushings. However, for kinematics purposes, spherical joints serve just as well in the model. To simplify the model, we have set the kingpin perpendicular to the ground. In reality, the kingpin is inclined slightly backward mainly to lessen steering effort required at near stationary speeds. The effect of the kingpin inclination angle is negligible at higher speeds.

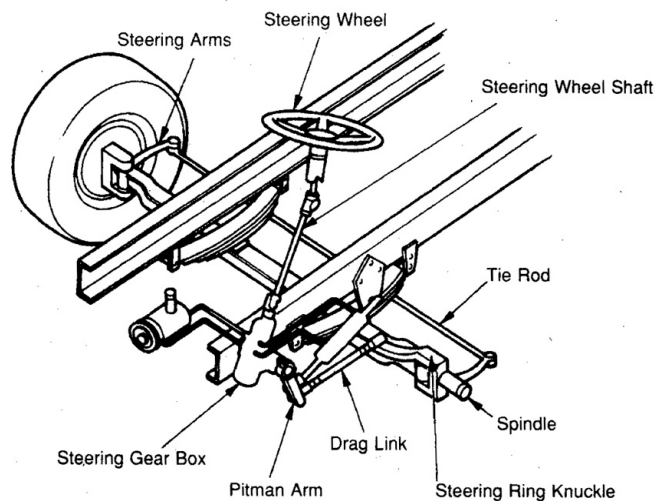

Figure 18: Steering linkage.

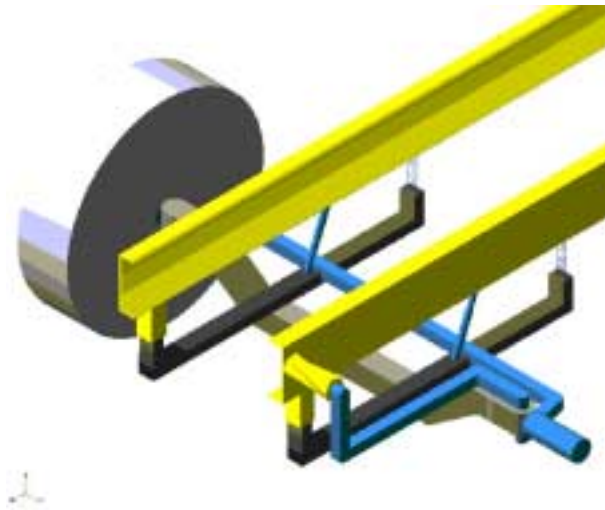

Figure 19: *ADAMS* front suspension and steering linkage.

The tandem axles of the tractor use an air suspension system (Figure 20). With the exception that it is softer, the air suspension behaves similarly to the front suspension, so we have modeled them the same way, only with a lower spring constant (Figure 21). An additional feature of the rear suspension is the pair of horizontal track rods that prevent the rear axles from moving laterally with respect to the frame. Again, we have replaced the revolute joint and bushing construction on the actual vehicle with a spherical joint in the model.

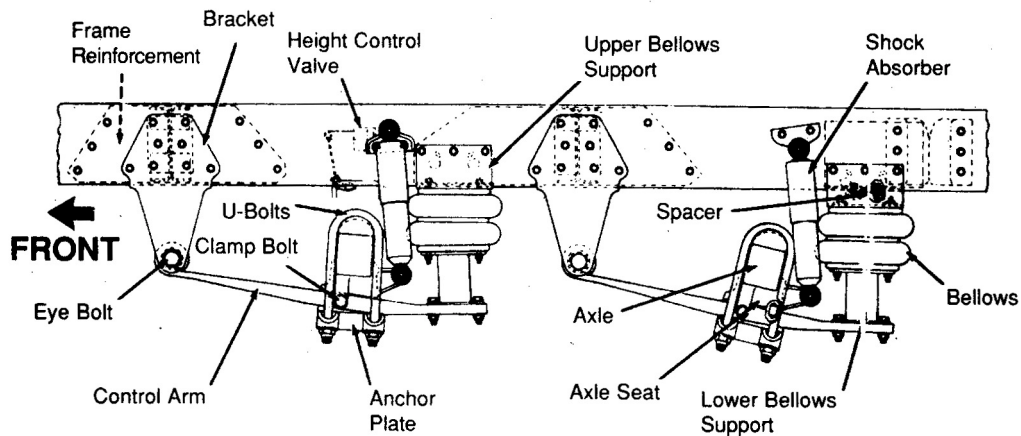

Figure 20: Rear suspension.

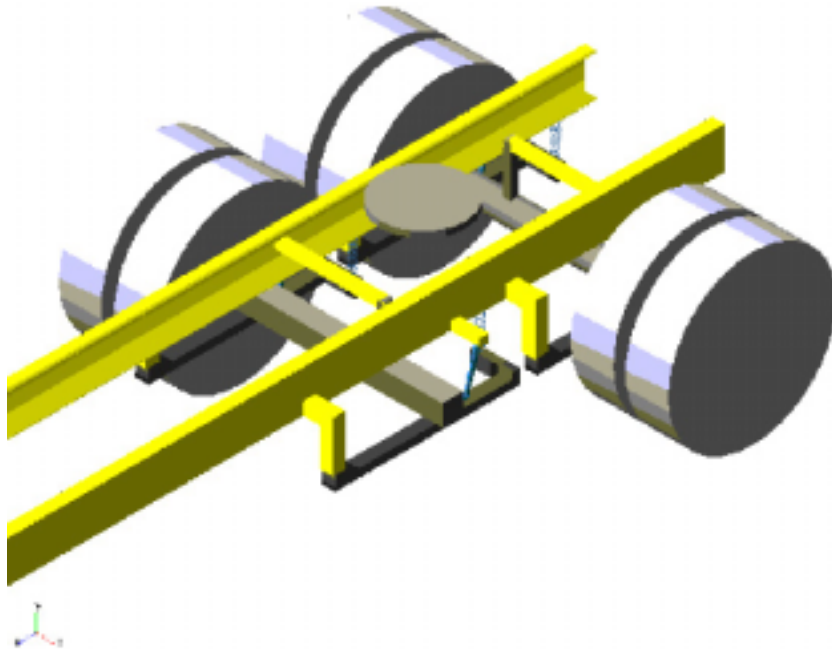

Figure 21: *ADAMS* rear suspension.

The semitrailer suspension, which consists four individual leaf springs, is known as a four-spring design. It employs a load equalization mechanism, which we have not modeled. Between the tractor and semitrailer, we reproduced a true fifth wheel junction. In other words, when the trailer is in line with the tractor, the trailer can pitch but not roll relative to the tractor. When the trailer is perpendicular to the tractor, the trailer can roll but not pitch.

The final major component of the model is the tires. The *ADAMS* modeling program contains a useful feature called *ADAMS/Tire*. During a full vehicle simulation, *ADAMS/Tire* solves for the tire forces based on one of several tire models such as the Delft tire model. Initially we had represented the dual tires as two separate tires attached to each other by a fixed joint, but to simplify the model and reduce simulation times, we are now using a single twice-as-wide tire in place of each dual unit.

4.2 Experimental verification

In order to verify the accuracy of the truck model, test data will be obtained from the PATH truck while performing lane change maneuvers. The lane-change maneuver is a useful test for evaluating vehicle performance for several reasons [10].

- It emphasizes the transient handling response of a vehicle by challenging its ability to change direction. The manner of roll, yaw, and slide slip response dictates how easily the driver (or a closed-loop controller) can maintain the desired path.
- It represents situations frequently encountered in normal driving, such as the need to swerve to avoid an obstacle on the highway.
- Results from the maneuver meaningfully differentiate performance between various types of vehicles.

We have selected the *Society of Automotive Engineers (SAE)* standard lane-change maneuver [1] for initial validation of the *ADAMS* heavy truck model. The lane-change maneuver defined by *SAE* is a high-speed (55 mph) test requiring 4.8 feet of lateral displacement over a distance of 200 feet. This maneuver is similar to the RTAC-b evasive maneuver developed by Ervin, et. al. [5] for the evaluation of three critical performance measures: rearward amplification, high-speed transient offtracking, and dynamic load transfer ratio. Test data for these performance measures will be compared with results from simulation. The model will be subsequently refined as needed.

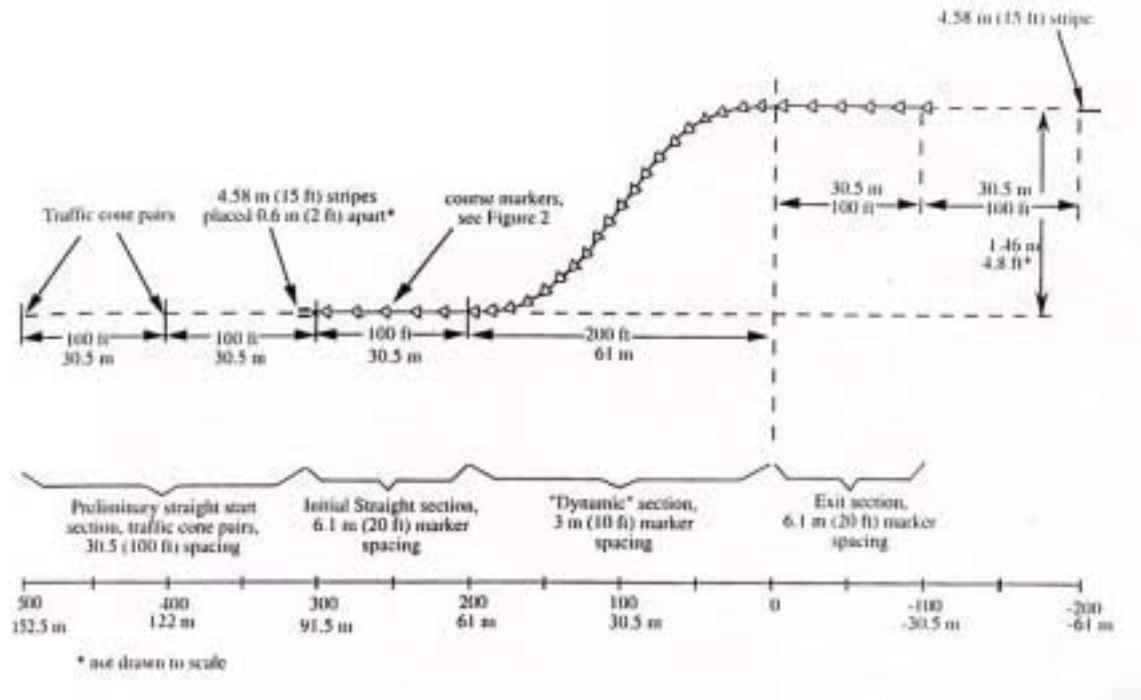

Figure 22: SAE lane change maneuver for articulated heavy vehicle.

5 Conclusion and Future Work

In this report, a performance-based framework has been established for evaluating heavy truck safety. The performance measures, compiled from an exhaustive search of the literature, provide a comprehensive picture of a truck's driving and handling characteristics on the road, e.g. its tendency to rollover in turns or how far its trailer swings into the opposing lane of traffic in an evasive maneuver. Exactly how these measures will be used to regulate safety remains to be seen. Some standards that have been suggested by researchers—rollover threshold, for example—consider the types of roads on which trucks travel, road curvature, road banking, and normal driving speed. Others may be based on experimental results or subjective feel.

Regulators must also look at how performance-based standards would be enforced. Current safety enforcement requires tremendous expenditures of time, effort and manpower: at the hundreds of weigh stations located throughout the interstate highway system, every truck passing the station must be weighed and subject to a thorough visual inspection. Faster, simpler, and more accurate methods for evaluating performance in each of the measures will have to be developed and will probably involve onboard diagnostic models with information coming from a few key sensors measuring, among other values, lateral acceleration, yaw, and roll rate. The models may require online estimation of parameters such as mass (which varies drastically with cargo load), center of gravity location (which varies with load distribution), or tire properties (which vary with tire normal load). The models will in turn predict any changes in performance due to load variations, tire wear, or even component failure. In a sense, the vehicle will constantly monitor itself by automatically evaluating its own level of performance.

Perhaps the most important use for performance measures is to give heavy vehicle designers a means for assessing the effect of a particular type of design on safety performance. The growing trend toward driver assistance systems (such as lane-departure warning and intelligent cruise control) and highway automation (as a part of the federal government's Intelligent Vehicle Highway Systems initiative) means that vehicles, ever more dependent on electronics and computer software, will become much too complex to analyze based on mere engineering intuition. Regardless of how complicated the system becomes, performance measures provide a systematic way of finding the answer to the question: is the design safe or unsafe? Because performance measures are quantitative measures, they also answer the question: which design is safer?

Future work under this project falls into two categories: 1) investigating methods for model reduction to generate simplified models suitable for controller design and onboard diagnostics, and 2) developing and evaluating advanced vehicle control schemes from the perspective of performance-based safety standards. The *ADAMS* multi-body dynamic model described in this report will serve as a baseline model for future model reduction work. Analytical work in robust model reduction techniques will proceed in accordance with the original project proposal. Examining the safety of vehicle controllers, both new and previously developed, requires the integration of the *ADAMS* heavy vehicle model with controllers existing in the *MATLAB Simulink* environment. Simulation results from

these safety evaluations combined with knowledge gained from applying model reduction techniques will lead to suggested redesigns of the controller-vehicle system that are safer as well as more robustly safe.

6 Acknowledgements

This work was sponsored by the California PATH program. The contents of this report reflect the views of the authors who are responsible for the facts and the accuracy of the data presented herein. The contents do not necessarily reflect the official views or policies of the state of California. This report does not constitute a standard, specification, or regulation. We also acknowledge the technical contributions of Dr. P. Hingwe, D. Nelson, P. Kretz, and S. Johnston.

7 References

- [1] A test for evaluating the rearward amplification of multi-articulated vehicles. Standard J2179, *Society of Automotive Engineers*, September 1993.
- [2] J. Billing. Configuration of heavy trucks with liftable axles. Technical paper 932993, *Society of Automotive Engineers*, 1993.
- [3] California Vehicle Code. <http://www.leginfo.ca.gov/calaw.html>
- [4] M. El-Gindy. Vehicle dynamics. Course notes, *The Pennsylvania State University*, Department of Mechanical Engineering, 1998.
- [5] R. Ervin and Y. Guy. The influence of weights and dimensions on the stability and control of heavy duty trucks in Canada. Technical report, *University of Michigan Transportation Research Institute*, July 1986.
- [6] P. Fancher. Directional dynamics considerations for multi-articulated, multi-axled heavy vehicles. Technical paper 892499, *Society of Automotive Engineers*, 1989.
- [7] P. Fancher and A. Mathew. A vehicle dynamics handbook for single-unit and articulated heavy trucks. Technical report, *University of Michigan Transportation Research Institute*, May 1987.
- [8] P. Fancher and A. Mathew. Safety implications of trucks designed to weigh over 80,000 pounds. Technical paper 891632, *Society of Automotive Engineers*, 1989.

- [9] P. Fancher and A. Mathew. Using a vehicle dynamics handbook as a tool for improving the steering and braking performances of heavy trucks.” Technical paper 870494, *Society of Automotive Engineers*, 1987.
- [10] P. Fancher, L. Segel, J. Bernard and R. Ervin. Test procedure for studying vehicle dynamics in lane-change maneuvers. Technical paper 760351, *Society of Automotive Engineers*, 1976.
- [11] P. Fancher, R. Ervin, C. Winkler and T. Gillespie. A Factbook of the Mechanical Properties of the Components for Single-Unit and Articulated Heavy Trucks. Technical report, *University of Michigan Transportation Research Institute*, 1986.
- [12] M. Pottinger, W. Pelz and G. Falciola. Effectiveness of the slip circle, ‘COMBINATOR’, model for combined tire cornering and braking force when applied to a range of tires. Technical paper 982747, *Society of Automotive Engineers*, 1998.
- [13] N. Vagstedt and E. Dahlberg. Determination of lateral axle data of heavy vehicle combinations. Technical paper 973188, *Society of Automotive Engineers*, 1997.
- [14] F. Wheeler and E. Johnson. Heavy truck axle alignment evolution—from the truck manufacturer to the user. Technical paper 933046, *Society of Automotive Engineers*, 1993.
- [15] C. Winkler and S. Bogard. Simple predictors of the performance of A-trains. Technical paper 932995, *Society of Automotive Engineers*, 1993.
- [16] C. Winkler, S. Bogard and S. Karamihas. Parameter measurements of highway tractor and semitrailer. Technical report UMTRI-95-47, *University of Michigan Transportation Research Institute*, December 1995.
- [17] C. Winkler, S. Karamihas and S. Bogard. Roll-stability performance of heavy-vehicle suspensions. Technical paper 922426, *Society of Automotive Engineers*, 1992.

8 Appendices

8.1 California vehicle code

8.1.1 Provisions on vehicle width

35100.

(a) The total outside width of any vehicle or its load shall not exceed 102 inches, except as otherwise provided in this chapter.

(b) Notwithstanding any other provision of law, safety devices which the Secretary of Transportation determines to be necessary for the safe and efficient operation of motor vehicles shall not be included in the calculation of width as specified in subdivision (a).

(c) Any city or county may, by ordinance, prohibit a combination of vehicles of a total width in excess of 96 inches upon highways under its jurisdiction. The ordinance shall not be effective until appropriate signs are erected indicating the streets affected.

35100.1.

For purposes of subdivision (a) of Section 35100, the following apply:

(a) The metric equivalent of 102 inches, 2.6 meters, meets the requirement of Section 35100.

(b) The width measurement of any vehicle with side walls shall be made from the outside wall of the two opposite sides of the vehicle.

35101.

When any vehicle is equipped with pneumatic tires, the maximum width from the outside of one wheel and tire to the outside of the opposite outer wheel and tire shall not exceed 108 inches, but the outside width of the body of the vehicle or the load thereon shall not exceed 102 inches. Vehicles manufactured, reconstructed, or modified after the effective date of amendments to this section enacted during the 1983 portion of the 1983-84 Regular Session of the Legislature, to utilize the 102 inch maximum width dimension, shall be equipped with axles, tires, and wheels of sufficient width to adequately and safely stabilize the vehicle. The Department of the California Highway Patrol shall conduct tests relating to the dynamic stability of vehicles utilizing body widths over 96 inches, up to and including 102 inches, to determine the necessity for establishing performance standards under the authority of Section 34500. Such standards if established shall be consistent with width standards established by or under the authority of the United States Department of Transportation.

35106.

(a) Motor coaches or buses may have a maximum width not exceeding 102 inches.

(b) Notwithstanding subdivision (a), motor coaches or buses operated under the jurisdiction of the Public Utilities Commission in urban or suburban service may have a maximum outside width not exceeding 104 inches, when approved by order of the Public

Utilities Commission for use on routes designated by it. Motor coaches or buses operated by common carriers of passengers for hire in urban or suburban service and not under the jurisdiction of the Public Utilities Commission may have a maximum outside width not exceeding 104 inches.

35109.

Lights, mirrors, or devices which are required to be mounted upon a vehicle under this code may extend beyond the permissible width of the vehicle to a distance not exceeding 10 inches on each side of the vehicle.

35110.

Door handles, hinges, cable cinchers, chain binders, and holders for the display of placards warning of hazardous materials may extend three inches on each side of the vehicle.

35111.

No passenger vehicle shall be operated on any highway with any load carried thereon extending beyond the line of the fenders on its left side or more than six inches beyond the line of the fender on its right side.

8.1.2 Provisions on vehicle height

35250.

No vehicle or load shall exceed a height of 14 feet measured from the surface upon which the vehicle stands, except that a double-deck bus may not exceed a height of 14 feet, 3 inches. Any vehicle or load which exceeds a height of 13 feet, 6 inches, shall only be operated on those highways where deemed to be safe by the owner of the vehicle or the entity operating the bus.

8.1.3 Provisions on vehicle length

35400.

(a) No vehicle shall exceed a length of 40 feet.

(b) This section does not apply to any of the following:

(1) A vehicle used in a combination of vehicles when the excess length is caused by auxiliary parts, equipment, or machinery not used as space to carry any part of the load, except that the combination of vehicles shall not exceed the length provided for combination vehicles.

(2) A vehicle when the excess length is caused by any parts necessary to comply with the fender and mudguard regulations of this code.

(3) An articulated bus or articulated trolley coach that does not exceed a length of 60 feet.

(4) A semitrailer while being towed by a motortruck or truck tractor, if the distance from the kingpin to the rearmost axle of the semitrailer does not exceed 40 feet for semitrailers having two or more axles, or 38 feet for semitrailers having one axle if the semitrailer does not, exclusive of attachments, extend forward of the rear of the cab of the motortruck or truck tractor.

(c) The Legislature, by increasing the maximum permissible kingpin to rearmost axle distance to 40 feet effective January 1, 1987, as provided in paragraph (4) of subdivision (b), does not intend this action to be considered a precedent for any future increases in truck size and length limitations.

35401.

(a) Except as provided in subdivisions (b), (c), and (d), no combination of vehicles coupled together, including any attachments, shall exceed a total length of 65 feet.

(b)

(1) A combination of vehicles coupled together, including any attachments, which consists of a truck tractor, a semitrailer, and a semitrailer or trailer, shall not exceed a total length of 75 feet, if the length of neither the semitrailers nor the trailer in the combination of vehicles exceeds 28 feet 6 inches.

(2) A B-train assembly is excluded from the measurement of semitrailer length when used between the first and second semitrailers of a truck tractor-semitrailer-semitrailer combination of vehicles. However, if there is no second semitrailer mounted to the B-train assembly, it shall be included in the length measurement of the semitrailer to which it is attached.

35401.1.

A combination of vehicles operated pursuant to Section 35400 or 35401 with a kingpin to rearmost axle measurement of greater than 38 feet but not more than 40 feet may be operated on those highways under the jurisdiction of local authorities only where it is deemed to be safe by the owner of the vehicle or the person operating the vehicle and where its operation is not specifically prohibited by local ordinance pursuant to subdivision (d) of Section 35401.

35401.3.

(a) Notwithstanding subdivisions (a) and (b) of Section 35401, a combination of vehicles designed and used to transport motor vehicles or boats, which consists of a motortruck and stinger-steered semitrailer, shall be allowed a length of up to 70 feet if the kingpin is at least 3 feet behind the rear drive axle of the motortruck. This combination shall not be subject to subdivision (a) of Section 35411, but the load upon the rear vehicle of the combination shall not extend more than 6 feet 6 inches beyond the allowable length of the vehicle.

(b) A combination of vehicles designed and used to transport motor vehicles or boats, which consists of a motortruck and stinger-steered semitrailer, shall be allowed a length of up to 75 feet if all of the following conditions are maintained:

(1) The distance from the steering axle to the rear drive axle of the motortruck does not exceed 24 feet.

(2) The kingpin is at least 5 feet behind the rear drive axle of the motortruck.

(3) The distance from the kingpin to the rear axle of the semitrailer does not exceed 34 feet except that the distance from the kingpin to the rear axle of a triple axle semitrailer does not exceed 36 feet.

This combination shall not be subject to subdivision (a) of Section 35411, but the load upon the rear vehicle of the combination shall not extend more than 6 feet 6 inches beyond the allowable length of the vehicle.

35401.5.

(a) A combination of vehicles consisting of a truck tractor and semitrailer, or of a truck tractor, semitrailer, and trailer, is not subject to the limitations of Sections 35400 and 35401, when operating on the National System of Interstate and Defense Highways or when using those portions of federal-aid primary system highways that have been qualified by the United States Secretary of Transportation for that use, or when using routes appropriately identified by the Department of Transportation or local authorities as provided in subdivision (c) or (d), if all of the following conditions are met:

(1) The length of the semitrailer in exclusive combination with a truck tractor does not exceed 48 feet. A semitrailer not more than 53 feet in length shall satisfy this requirement when configured with two or more rear axles, the rearmost of which is located 40 feet or less from the kingpin or when configured with a single axle which is located 38 feet or less from the kingpin. For purposes of this paragraph, a motortruck used in combination with a semitrailer, when that combination of vehicles is engaged solely in the transportation of motor vehicles or boats, is considered to be a truck tractor.

(2) Neither the length of the semitrailer nor the length of the trailer when simultaneously in combination with a truck tractor exceeds 28 feet 6 inches.

35406.

(a) Except as provided in subdivision (b), the load upon any vehicle operated alone, or the load upon the front vehicle of a combination of vehicles, shall not extend more than three feet beyond the foremost part of the front tires of the vehicle or the front bumper of the vehicle, if it is equipped with a front bumper.

(b) When the load is composed solely of vehicles, the load upon the front vehicle of a combination of vehicles shall not extend more than four feet beyond the foremost part of the front tires of the vehicle or the front bumper of the vehicle, if it is equipped with a front bumper.

35410.

The load upon any motor vehicle alone or an independent load only upon a trailer or semitrailer shall not extend to the rear beyond the last point of support for a greater distance than that equal to two-thirds of the length of the wheelbase of the vehicle carrying such load, except that the wheelbase of a semitrailer shall be considered as the distance between the rearmost axle of the towing vehicle and the rearmost axle of the semitrailer.

35411.

(a) Except as provided in subdivision (b), the load upon any combination of vehicles shall not exceed 75 feet measured from the front extremity of the front vehicle or load to the rear extremity of the last vehicle or load.

(b) The load upon any combination of vehicles operating pursuant to Section 35401 or 35401.5, when the overall length of the combination of vehicles exceeds 75 feet, shall be confined within the exterior dimensions of the vehicles.

8.1.4 Provisions on vehicle weight

35550.

(a) The gross weight imposed upon the highway by the wheels on any one axle of a vehicle shall not exceed 20,000 pounds and the gross weight upon any one wheel, or wheels, supporting one end of an axle, and resting upon the roadway, shall not exceed 10,500 pounds.

(b) The gross weight limit provided for weight bearing upon any one wheel, or wheels, supporting one end of an axle shall not apply to vehicles the loads of which consist of livestock.

(c) The maximum wheel load is the lesser of the following:

(1) The load limit established by the tire manufacturer, as molded on at least one sidewall of the tire.

(2) A load of 620 pounds per lateral inch of tire width, as determined by the manufacturer's rated tire width as molded on at least one sidewall of the tire for all axles except the steering axle, in which case paragraph (1) applies.

35551.

(a) Except as otherwise provided in this section or Section 35551.5, the total gross weight in pounds imposed on the highway by any group of two or more consecutive axles shall not exceed that given for the respective distance in the following table:

Distance in feet between the extremes of any group of 2 or more consecutive axles	2 axles	3 axles	4 axles	5 axles	6 axles
4	34,000	34,000	34,000	34,000	34,000
5	34,000	34,000	34,000	34,000	34,000
6	34,000	34,000	34,000	34,000	34,000
7	34,000	34,000	34,000	34,000	34,000
8	34,000	34,000	34,000	34,000	34,000
9	39,000	42,500	42,500	42,500	42,500
10	40,000	43,500	43,500	43,500	43,500
11	40,000	44,000	44,000	44,000	44,000
12	40,000	45,000	50,000	50,000	50,000
13	40,000	45,500	50,500	50,500	50,500
14	40,000	46,500	51,500	51,500	51,500
15	40,000	47,000	52,000	52,000	52,000

Distance in feet between the extremes of any group of 2 or more consecutive axles	2 axles	3 axles	4 axles	5 axles	6 axles
16	40,000	48,000	52,500	52,500	52,500
17	40,000	48,500	53,500	53,500	53,500
18	40,000	49,500	54,000	54,000	54,000
19	40,000	50,000	54,500	54,500	54,500
20	40,000	51,000	55,500	55,500	55,500
21	40,000	51,500	56,000	56,000	56,000
22	40,000	52,500	56,500	56,500	56,500
23	40,000	53,000	57,500	57,500	57,500
24	40,000	54,000	58,000	58,000	58,000
25	40,000	54,500	58,500	58,500	58,500
26	40,000	55,500	59,500	59,500	59,500
27	40,000	56,000	60,000	60,000	60,000
28	40,000	57,000	60,500	60,500	60,500
29	40,000	57,500	61,500	61,500	61,500
30	40,000	58,500	62,000	62,000	62,000
31	40,000	59,000	62,500	62,500	62,500
32	40,000	60,000	63,500	63,500	63,500
33	40,000	60,000	64,000	64,000	64,000
34	40,000	60,000	64,500	64,500	64,500
35	40,000	60,000	65,500	65,500	65,500
36	40,000	60,000	66,000	66,000	66,000
37	40,000	60,000	66,500	66,500	66,500
38	40,000	60,000	67,500	67,500	67,500
39	40,000	60,000	68,000	68,000	68,000
40	40,000	60,000	68,500	70,000	70,000
41	40,000	60,000	69,500	72,000	72,000
42	40,000	60,000	70,000	73,280	73,280
43	40,000	60,000	70,500	73,280	73,280
44	40,000	60,000	71,500	73,280	73,280
45	40,000	60,000	72,000	76,000	80,000
46	40,000	60,000	72,500	76,500	80,000
47	40,000	60,000	73,500	77,500	80,000
48	40,000	60,000	74,000	78,000	80,000
49	40,000	60,000	74,500	78,500	80,000
50	40,000	60,000	75,500	79,000	80,000
51	40,000	60,000	76,000	80,000	80,000
52	40,000	60,000	76,500	80,000	80,000
53	40,000	60,000	77,500	80,000	80,000
54	40,000	60,000	78,000	80,000	80,000
55	40,000	60,000	78,500	80,000	80,000
56	40,000	60,000	79,500	80,000	80,000
57	40,000	60,000	80,000	80,000	80,000
58	40,000	60,000	80,000	80,000	80,000
59	40,000	60,000	80,000	80,000	80,000
60	40,000	60,000	80,000	80,000	80,000

(b) In addition to the weights specified in subdivision (a), two consecutive sets of tandem axles may carry a gross weight of 34,000 pounds each if the overall distance between the first and last axles of the consecutive sets of tandem axles is 36 feet or more. The gross weight of each set of tandem axles shall not exceed 34,000 pounds and the gross weight of the two consecutive sets of tandem axles shall not exceed 68,000 pounds.

(c) The distance between axles shall be measured to the nearest whole foot. When a fraction is exactly six inches, the next larger whole foot shall be used.

(d) Nothing contained in this section shall affect the right to prohibit the use of any highway or any bridge or other structure thereon in the manner and to the extent specified in Article 4 (commencing with Section 35700) and Article 5 (commencing with Section 35750) of this chapter.

(e) The gross weight limits expressed by this section and Section 35550 shall include all enforcement tolerances.

35551.5.

(a) The provisions of this section shall apply only to combinations of vehicles which contain a trailer or semitrailer. Each vehicle in such combination of vehicles, and every such combination of vehicles, shall comply with either Section 35551 or with subdivisions (b), (c), and (d) of this section.

(b) The gross weight imposed upon the highway by the wheels on any one axle of a vehicle shall not exceed 18,000 pounds and the gross weight upon any one wheel, or wheels, supporting one end of an axle and resting upon the roadway, shall not exceed 9,500 pounds, except that the gross weight imposed upon the highway by the wheels on any front steering axle of a motor vehicle shall not exceed 12,500 pounds. The gross weight limit provided for weight bearing upon any one wheel, or wheels, supporting one end of an axle shall not apply to vehicles the loads of which consist of livestock. The following vehicles are exempt from the front axle weight limits specified in this subdivision:

- (1) Trucks transporting vehicles.
- (2) Trucks transporting livestock.
- (3) Dump trucks.
- (4) Cranes.
- (5) Buses.
- (6) Transit mix concrete or cement trucks, and trucks that mix concrete or cement at, or adjacent to, a jobsite.
- (7) Motor vehicles that are not commercial vehicles.
- (8) Vehicles operated by any public utility furnishing electricity, gas, water, or telephone service.
- (9) Trucks or truck tractors with a front axle at least four feet to the rear of the foremost part of the truck or truck tractor, not including the front bumper.
- (10) Trucks transporting garbage, rubbish, or refuse.
- (11) Trucks equipped with a fifth wheel when towing a semitrailer.
- (12) Tank trucks which have a cargo capacity of at least 1,500 gallons.
- (13) Trucks transporting bulk grains or bulk livestock feed.

(c) The total gross weight with load imposed on the highway by any group of two or more consecutive axles of a vehicle in such combination of vehicles or of such

combination of vehicles where the distance between the first and last axles of the two or more consecutive axles is 18 feet or less shall not exceed that given for the respective distance in the following table:

Distance in feet between first and last axles of group	Allowed load in pounds on group of axles
4	32,000
5	32,000
6	32,200
7	32,900
8	33,600
9	34,300
10	35,000
11	35,700
12	36,400
13	37,100
14	43,200
15	44,000
16	44,800
17	45,600
18	46,400

(d) The total gross weight with load imposed on the highway by any vehicle in such combination of vehicles or of such combination of vehicles where the distance between the first and last axles is more than 18 feet shall not exceed that given for the respective distances in the following table below.

(e) The distance between axles shall be measured to the nearest whole foot. When a fraction is exactly six inches, the next larger whole foot shall be used.

(f) The gross weight limits expressed by this section shall include all enforcement tolerances.

(g) Nothing in this section shall affect the right to prohibit the use of any highway or any bridge or other structure thereon in the manner and to the extent specified in Article 4 (commencing with Section 35700) and Article 5 (commencing with Section 35750) of Chapter 5 of Division 15.

(h) The Legislature, in enacting this section, does not intend to increase, and this section shall not be construed to allow, statutory weights any greater than existed prior to January 1, 1976.

Distance in feet	Allowed load in pounds
19	47,200
20	48,000
21	48,800
22	49,600
23	50,400
24	51,200
25	55,250
26	56,100
27	56,950
28	57,800
29	58,650
30	59,500
31	60,350
32	61,200
33	62,050
34	62,900
35	63,750
36	64,600
37	65,450
38	66,300
39	68,000
40	70,000
41	72,000
42	73,280
43	73,280
44	73,280
45	73,280
46	73,280
47	73,280
48	73,280
49	73,280
50	73,280
51	73,280
52	73,600
53	74,400
54	75,200
55	76,000
56	76,800

35552.

(a) This section applies only to trucks and vehicle combinations while transporting loads composed solely of logs.

(b) One set of tandem axles of such a truck or vehicle combination shall be deemed to be in compliance with Section 35551 if the total gross weight of 34,000 pounds on such a set that is permitted by Section 35551 is not exceeded by more than 1,500 pounds. In addition, such a truck and vehicle combination that has two consecutive sets of tandem axles shall be deemed to be in compliance with Section 35551 if such consecutive sets of

tandem axles do not carry a combined total gross weight of more than 69,000 pounds, if the total gross weight on any one such set does not exceed 35,500 pounds, and if the overall distance between the first and last axle of such consecutive sets of tandem axles is 34 feet or more. All such truck and vehicle combinations shall be subject to all other provisions of Section 35551 or any other provision made applicable to the total gross weight of such a truck or vehicle combination in lieu of Section 35551.

(c) The gross weight limits expressed in this section shall include all enforcement tolerances.

(d) If any total gross weight permitted by this section is exceeded, the allowed weight in pounds set forth in subdivision (a) of Section 35551 shall be the maximum permitted weight for purposes of determining the amount of fine for such violation as specified in the table in Section 42030; except that, whenever the violation is for exceeding the total gross weight for two consecutive sets of tandem axles, and if the overall distance between the first and last axle of such sets is 34 feet or more, the allowed weight on the two consecutive sets shall be 68,000 pounds.

(e) This section shall have no application to highways which are a part of the National System of Interstate and Defense Highways (as referred to in subdivision (a) of Section 108 of the Federal-aid Highway Act of 1956).

This section may be cited as the Christensen-Belotti Act.

35553.

The provisions of this article shall not apply to any vehicle in the immediate vicinity of an unloading or loading area while actually preparing for or in the process of unloading or loading, provided any overload is incidental to and necessitated by such action; and provided that such action does not occur on a bridge or highway structure.

This section shall have no application to highways which are a part of the national system of interstate and defense highways (as referred to in subdivision (a) of Section 108 of the Federal-aid Highway Act of 1956).

35554.

Notwithstanding Section 35550, the gross weight on any one axle of a bus shall not exceed 20,500 pounds.

35555.

During the period commencing September 15 of each year and ending March 15 of the following year, the weight limitations of Section 35551 do not apply to any cotton module mover or any truck tractor pulling a semitrailer that is a cotton module mover, when operated as follows:

(a) Laterally across a state highway at grade of the state highway.

(b) Upon any county highway within the Counties of Butte, Colusa, Fresno, Glenn, Imperial, Kern, Kings, Madera, Merced, Riverside, Sacramento, San Benito, San Bernardino, San Joaquin, Stanislaus, Sutter, Tehama, Tulare, Yolo, and Yuba except as prohibited or limited on county highways or portions thereof by resolution of the county board of supervisors having jurisdiction.

35557.

(a) Only upon request to, and approval by, and in accordance with regulations adopted by, the Director of Food and Agriculture, all of the following are available for inspection by district attorneys and are subject to legal process for admission in any criminal or civil proceeding arising out of a violation of this chapter:

(1) Vehicle weight certificates issued on or after January 1, 1984, pursuant to Chapter 7 (commencing with Section 12700), Chapter 7.3 (commencing with Section 12740), and Chapter 7.7 (commencing with Section 12770) of Division 5 of the Business and Professions Code.

(2) Other records of vehicle weight relating to those certificates.

(3) Copies of those certificates and records.

(b) All certificates, records, and copies thereof, issued before January 1, 1984, shall not be available for inspection and are not admissible in any criminal or civil proceedings arising out of a violation of this chapter.

35558.

Any person or business which has an axle weight scale at its loading facilities shall, upon the request of the driver, weigh any load being transported for that person or business before the vehicle leaves the loading facility. In a port facility, this requirement only applies if the scale is located in outbound lanes. The request to weigh shall be based upon a reasonable assumption that the load is overweight.

35559.

Whenever a person, charged with a violation of this chapter, shows to the satisfaction of the court that the person conducted his or her activities pursuant to a gross cargo weight verification issued in accordance with Section 508 of Title 49 of the United States Code and that the verification specifies a stated gross cargo weight which could be lawfully transported by the equipment on which the cargo was loaded, the court shall, on request of the person so charged, take appropriate steps to make the party which issued the verification a codefendant. In the event the court finds that the party which issued the verification misrepresented the gross cargo weight and that party is held solely responsible and found guilty, the court may dismiss the charges against the person who received the gross cargo weight verification.

8.2 References for parameters and performance measures

8.2.1 Reference details by date

8.2.1.1 *Society of Automotive Engineers* technical papers

Document Number:	680547
Title:	Optimum braking, stability and structural integrity for longer truck combinations
Publication Date:	1968
Author(s):	Nelson, Robert E.; Fitch, James W.
Organization(s):	American Brakeblok Div., Abex Corp.; Western Highway Inst.
Meeting:	National West Coast Meeting
Meeting Location:	San Francisco, California, USA
Meeting Start Dat	12-Aug-68
Index Terms:	Brakes; Truck trailers
SAE Transaction:	Vol. 77 (1968)
Document Type:	Technical Papers

Document Number:	700377
Title:	An analysis of tire traction properties and their influence on vehicle dynamic Performance
Publication Date:	1970
Author(s):	Dugoff, Howard; Fancher, P. S.; Segel, Leonard
Organization(s):	Highway Safety Research Institute, Univ. of Michigan; Highway Safety Research Institute, Univ. of Michigan; Highway Safety Research Institute, Univ. of Michigan
Meeting:	International Automobile Safety Conference
Meeting Location:	Detroit, Michigan, USA
Meeting Start Date:	13-May-70
Book containing this paper	P-30
Index Terms:	Computer simulation; Tires
SAE Transaction:	Vol. 79 (1970)
Document Type:	Technical Papers

Document Number:	710044
Title:	Investigation of the brake force distribution on tractor-semitrailer combinations
Publication Date:	1971
Author(s):	Limpert, Rudolf
Organization(s):	The University of Michigan
Meeting:	Automotive Engineering Congress and Exposition
Meeting Location:	Detroit, Michigan, USA
Meeting Start Dat	11-Jan-71
Index Terms:	Truck trailers; Brakes
SAE Transaction:	Vol. 80 (1971)
Document Type:	Technical Papers

Document Number:	730182
Title:	Measurement of inertial properties and suspension parameters of heavy highway vehicles
Publication Date:	1973
Author(s):	Winkler, Christopher B.
Organization(s):	Highway Safety Research Inst., University of Michigan
Meeting:	International Automotive Engineering Congress and Exposition
Meeting Location:	Detroit, Michigan, USA
Meeting Start Dat	8-Jan-73
Index Terms:	Suspension systems; Truck tractors; Test equipment; Springs
SAE Transaction:	Vol. 82 (1973)
Document Type:	Technical Papers
Document Number:	730183
Title:	Mechanical properties of truck tires
Publication Date:	1973
Author(s):	Tielking, J. T.; Fancher, P. S.; Wild, R. E.
Organization(s):	Highway Safety Research Inst., The University of Michigan; Highway Safety Research Inst., The University of Michigan; Highway Safety Research Inst., The University of Michigan
Meeting:	International Automotive Engineering Congress and Exposition
Meeting Location:	Detroit, Michigan, USA
Meeting Start Dat	8-Jan-73
Index Terms:	Tires
Document Type:	Technical Papers
Document Number:	730673
Title:	Parameter studies in articulated vehicle handling
Publication Date:	1973
Author(s):	Eshleman, R. L.; Scopelite, T. M.; Desai, S.
Organization(s):	IIT Research Inst.; IIT Research Inst.; IIT Research Inst.
Meeting:	Fleet Week
Meeting Location:	Chicago, Illinois, USA
Meeting Start Date	18-Jun-73
Index Terms:	Truck trailers; Vehicle directional control; Truck operation; Computer simulation
Document Type:	Technical Papers
Document Number:	740136
Title:	Analysis and computer simulation of the four elliptical leaf spring tandem suspension
Publication Date:	1974
Author(s):	Winkler, C. B.
Organization(s):	Highway Safety Res. Inst., The Univ. of Mich.
Meeting:	Automotive Engineering Congress and Exposition
Meeting Location:	Detroit, Michigan, USA
Meeting Start Dat	25-Feb-74
Index Terms:	Simulation; Truck operation; Truck design; Suspension systems
SAE Transaction:	Vol. 83 (1974)
Document Type:	Technical Papers

Document Number:	741139
Title:	Preliminary measurements of the longitudinal traction properties of truck tires
Publication Date:	1974
Author(s):	Ervin, Robert D.; Fancher, Paul S.
Organization(s):	Highway Safety Research Institute, Univ. of Michigan; Highway Safety Research Institute, Univ. of Michigan
Meeting:	National Truck Meeting
Meeting Location:	Troy, Michigan, USA
Meeting Start Dat	4-Nov-74
Index Terms:	Tires; Truck operation; Test equipment; Dynamometers
Document Type:	Technical Papers
Document Number:	750210
Title:	Torque characteristics of commercial vehicle brakes
Publication Date:	1975
Author(s):	Post, Thomas M.; Fancher, Paul S.; Bernard, James E.
Organization(s):	Highway Safety Research Institute, University of Michigan; Highway Safety Research Institute, University of Michigan; Highway Safety Research Institute, University of Michigan
Meeting:	Automotive Engineering Congress and Exposition
Meeting Location:	Detroit, Michigan, USA
Meeting Start Dat	24-Feb-75
Index Terms:	Brakes; Dynamometers
Document Type:	Technical Papers
Document Number:	750398
Title:	A braking efficiency test technique
Publication Date:	1975
Author(s):	Winkler, Christopher B.; Ervin, Robert D.
Organization(s):	University of Michigan; University of Michigan
Meeting:	Automotive Engineering Congress and Exposition
Meeting Location:	Detroit, Michigan, USA
Meeting Start Dat	24-Feb-75
Index Terms:	Brakes; Safety; Dynamometers; Tires
SAE Transaction:	Vol. 84 (1975)
Document Type:	Technical Papers
Document Number:	760025
Title:	Front brake interactions with heavy vehicle steering and handling during braking
Publication Date:	1976
Author(s):	Gillespie, T. D.
Organization(s):	Ford Motor Co.
Meeting:	Automotive Engineering Congress and Exposition
Meeting Location:	Detroit, Michigan, USA
Meeting Start Dat	23-Feb-76
Index Terms:	Steering; Brakes; Computer simulation; Vehicle dynamics; Vehicle directional control; Air brakes
SAE Transaction:	Vol. 85 (1976)
Document Type:	Technical Papers

Document Number: 781065
Title: Analysis of the rollover dynamics of double-bottom tankers
Publication Date: 1978
Author(s): Gillespie, T. D.; Verma, M. K.
Organization(s): Highway Safety Research Institute, The Univ. of Michigan; Highway Safety Research Institute, The Univ. of Michigan
Meeting: National Truck Meeting
Meeting Location: Dearborn, Michigan, USA
Meeting Start Dat: 11-Dec-78
Index Terms: Truck design; Truck operation
Document Type: Technical Papers

Document Number: 800905
Title: Measurement and representation of the mechanical properties of truck leaf springs
Publication Date: 1980
Author(s): Fancher, P. S.; Ervin, R. D.; MacAdam, C. C.; Winkler, C. B.
Organization(s): Highway Safety Research Institute, The Univ. of Michigan; Highway Safety Research Institute, The Univ. of Michigan; Highway Safety Research Institute, The Univ. of Michigan; Highway Safety Research Institute, The Univ. of Michigan
Meeting: West Coast International Meeting
Meeting Location: Los Angeles, California, USA
Meeting Start Dat: 11-Aug-80
Index Terms: Vehicle dynamics; Truck tractors; Truck trailers; Springs; Suspension systems
Document Type: Technical Papers

Document Number: 800906
Title: A test facility for the measurement of heavy vehicle suspension parameters
Publication Date: 1980
Author(s): Winkler, Christopher B.; Hagan, Michael
Organization(s): Highway Safety Research Institute, The Univ. of Michigan; Highway Safety Research Institute, The Univ. of Michigan
Meeting: West Coast International Meeting
Meeting Location: Los Angeles, California, USA
Meeting Start Dat: 11-Aug-80
Index Terms: Suspension systems; Springs; Test facilities; Test equipment; Truck operation
SAE Transaction: Vol. 89 (1980)
Document Type: Technical Papers

Document Number: 821259
Title: The transient directional response of full trailers
Publication Date: 1982
Author(s): Fancher, Paul S.
Organization(s): The University of Michigan, Transportation Research Institute
Meeting: Truck and Bus Meeting Exposition
Meeting Location: Indianapolis, Indiana, USA
Meeting Start Dat: 8-Nov-82
Index Terms: Vehicle dynamics; Vehicle directional control; Trailers; Truck trailers; Steering
SAE Transaction: Vol. 91 (1982)

Document Type: Technical Papers

Document Number: 821260
Title: A computer-based study of the yaw/roll stability of heavy trucks characterized by high centers of gravity
Publication Date: 1982
Author(s): MacAdam, Charles C.
Organization(s): The University of Michigan, Transportation Research Institute
Meeting: Truck and Bus Meeting Exposition
Meeting Location: Indianapolis, Indiana, USA
Meeting Start Dat: 8-Nov-82
Index Terms: Stability; Vehicle directional control; Truck design; Vehicle dynamics; Computer simulation
SAE Transaction: Vol. 91 (1982)
Document Type: Technical Papers

Document Number: 831162
Title: Improved stability and handling of truck combinations with the double drawbar dolly
Publication Date: 1983
Author(s): Woodrooffe, J. H. F.; Billing, J. R.; Nisonger, R. L.
Organization(s): National Research Council of Canada; Ontario Ministry of Transportation and Communications; University of Michigan Transportation Research Institute
Meeting: West Coast International Meeting
Meeting Location: Vancouver, British Columbia, Canada
Meeting Start Dat: 8-Aug-83
Index Terms: Truck operation; Vehicle performance; Tests; Axles; Computer simulation
Document Type: Technical Papers

Document Number: 831788
Title: Directional control of retarder-equipped heavy trucks operating on slippery surfaces
Publication Date: 1983
Author(s): Fancher, P. S.; Radlinski, R. W.
Organization(s): Transportation Research Institute, The University of Michigan; Vehicle Research and Test Center, National Highway Traffic Safety Administration
Meeting: Truck and Bus Meeting and Exposition
Meeting Location: Cleveland, Ohio, USA
Meeting Start Dat: 7-Nov-83
Index Terms: Truck operation; Retarders; Control systems
SAE Transaction: Vol. 92 (1983)
Document Type: Technical Papers

Document Number: 845063
Title: The braking safety of heavy commercial vehicles and its assessment with special regard to relevant properties of the vehicle and braking system
Publication Date: 1984
Author(s): Hoffmann, H. J.; Breuer, B.
Meeting: 20th FISITA Congress (1984), Vienna, Austria
Index Terms: Brakes; Truck design
Document Type: Technical Papers

Document Number: 850537
Title: Steady-state steering response of an articulated vehicle with a multi-axle forced steering dolly
Publication Date: 1985
Author(s): El-Gindy, M.; Wong, J. Y.
Organization(s): Transport Technology Research Laboratory, Carleton University, Ottawa, Canada; Transport Technology Research Laboratory, Carleton University, Ottawa, Canada
Meeting: International Congress and Exposition
Meeting Location: Detroit, Michigan, USA
Meeting Start Date: 25-Feb-85
Index Terms: Truck design; Truck operation; Steering; Truck stability; Truck tractors; Models
Document Type: Technical Papers

Document Number: 852334
Title: Method of graphically determining path of trailer off-tracking in turns
Publication Date: 1985
Author(s): Carter, Don L.
Organization(s): IRI International
Meeting: 3rd International Pacific Conference on Automotive Engineering
Meeting Location: Jakarta, Indonesia
Meeting Start Date: 11-Nov-85
Index Terms: Truck dynamics; Truck handling; Truck trailers handling; Mathematical analysis; Graphics
Document Type: Technical Papers

Document Number: 852335
Title: Steering response of articulated vehicles in steady-state turns
Publication Date: 1985
Author(s): El-Gindy, M.; Wong, J. Y.
Organization(s): Transport Technology Research Laboratory, Carleton Univ., Ottawa, Canada; Transport Technology Research Laboratory, Carleton Univ., Ottawa, Canada
Meeting: 3rd International Pacific Conference on Automotive Engineering
Meeting Location: Jakarta, Indonesia
Meeting Start Date: 11-Nov-85
Index Terms: Truck dynamics; Steering; Truck handling; Truck cornering; Truck operation; Cornering; Axles; Truck stability; Truck tractors stability; Truck trailers stability
Document Type: Technical Papers

Document Number: 852333
Title: A generalized solution of non-steady state vehicle off tracking in constant radius curves
Publication Date: 1985
Author(s): Woodroffe, J. H. F.; Smith, C. A. M.; Morisset, L. E.
Organization(s): National Research Council of Canada; National Research Council of Canada; University of Ottawa
Meeting: 3rd International Pacific Conference on Automotive Engineering
Meeting Location: Jakarta, Indonesia
Meeting Start Date: 11-Nov-85
Index Terms: Truck dynamics; Truck handling; Truck trailers handling; Mathematical analysis; Models
Document Type: Technical Papers

Document Number: 870334
Title: The influence of braking efficiency on the probability of wheel lockup
Publication Date: 1987
Author(s): Ervin, R. D.; Winkler, C. B.
Organization(s): The Univ. of Michigan, Transportation Research Institute; The Univ. of Michigan, Transportation Research Institute
Meeting: SAE International Congress and Exposition
Meeting Location: Detroit, Michigan, USA
Meeting Start Date: 23-Feb-87
Index Terms: Braking; Antiskid devices; Probability theory; Friction; Failure
SAE Transaction: Vol. 96 (1987), Section(s) 1
Document Type: Technical Papers

Document Number: 870494
Title: Using a vehicle dynamics handbook as a tool for improving the steering and braking performances of heavy trucks
Publication Date: 1987
Author(s): Fancher, P. S.; Mathew, A.
Organization(s): Transportation Research Institute, The Univ. of Michigan; Transportation Research Institute, The Univ. of Michigan
Meeting: SAE International Congress and Exposition
Meeting Location: Detroit, Michigan, USA
Meeting Start Date: 23-Feb-87
Book containing this paper SP-699
Index Terms: Vehicle dynamics; Truck dynamics; Steering; Braking; Mechanical efficiency
Document Type: Technical Papers

Document Number: 871180
Title: The dynamic stability testing of articulated vehicles
Publication Date: 1987
Author(s): Tso, Y.; Sweatman, P.
Organization(s): Australian Road Research Board; Australian Road Research Board
Meeting: 4th International Pacific Conference on Automotive Engineering
Meeting Location: Melbourne, Australia
Meeting Start Date: 8-Nov-87
Book containing this paper P-212
Index Terms: Vehicle dynamics; Truck dynamics; Rolling; Trailer accidents; Tests
Document Type: Technical Papers

Document Number: 885111
Title: A comparison of the dynamic performance of a U.S. and a European heavy vehicle
Publication Date: 1988
Author(s): Gillespie, Thomas D.; Radlinski, Richard; Flick, Mark
Meeting: 22nd FISITA Congress (1988), Dearborn, Michigan, USA
Book containing this paper P-211
Index Terms: Truck trailers handling; Truck dynamics; Truck cornering; Braking; Computer simulation; Truck design
Document Type: Technical Papers

Document Number: 891198
Title: A unified tire model for braking driving and steering simulation
Publication Date: 1989
Author(s): Guo, Kong-Hui
Organization(s): Changchun Automotive Research Institute
Meeting: 5th International Pacific Conference on Automotive Engineering
Meeting Location: Beijing, China
Meeting Start Date: 5-Nov-89
Index Terms: Tires; Models; Simulation; Braking; Steering; Vehicle dynamics
Document Type: Technical Papers

Document Number: 891632
Title: Safety implications of trucks designed to weigh over 80,000 pounds
Publication Date: 1989
Author(s): Fancher, Paul S. @sJr.; Mathew, Arvid
Organization(s): University of Michigan, Transportation Research Institute; University of Michigan, Transportation Research Institute
Meeting: Conference and Exposition on Future Transportation Technology
Meeting Location: Vancouver, British Columbia, Canada
Meeting Start Date: 7-Aug-89
Index Terms: Truck design; Truck safety; Highways; Truck tractors; Truck trailers; Truck tractors handling
SAE Transaction: Vol. 98 (1989), Section(s) 2
Document Type: Technical Papers

Document Number: 891633
Title: Self-steering axles~Theory and practice
Publication Date: 1989
Author(s): LeBlanc, P. A.; El-Gindy, M.; Woodrooffe, J. H. F.
Organization(s): National Research Council Canada; National Research Council Canada; National Research Council Canada
Meeting: Conference and Exposition on Future Transportation Technology
Meeting Location: Vancouver, British Columbia, Canada
Meeting Start Date: 7-Aug-89
Index Terms: Truck design; Axles; Truck handling; Steering; Braking
SAE Transaction: Vol. 98 (1989), Section(s) 2
Document Type: Technical Papers

Document Number: 892461
Title: Vehicle design implications of the turner proposal
Publication Date: 1989
Author(s): Fancher, Paul S.; Campbell, Kenneth L.; Blower, Daniel F.
Organization(s): Transportation Research Institute, University of Michigan; Transportation Research Institute, University of Michigan; Transportation Research Institute, University of Michigan
Meeting: Truck and Bus Meeting and Exposition
Meeting Location: Charlotte, North Carolina, USA
Meeting Start Date: 6-Nov-89
Index Terms: Performance; Truck design; Surfaces; Safety; Tractor (truck) design; Loads

SAE Transaction: Vol. 98 (1989), Section(s) 2
Document Type: Technical Papers

Document Number: 892480

Title: Influence of tank design factors on the rollover threshold of partially filled tank vehicles
Publication Date: 1989
Author(s): Rakheja, S.; Sankar, S.; Ranganathan, R.
Organization(s): Dept. of Mech. Engrg., Concordia Univ., Montreal, Quebec, Canada; Dept. of Mech. Engrg., Concordia Univ., Montreal, Quebec, Canada; Dept. of Mech. Engrg., Concordia Univ., Montreal, Quebec, Canada
Meeting: Truck and Bus Meeting and Exposition
Meeting Location: Charlotte, North Carolina, USA
Meeting Start Date: 6-Nov-89
Index Terms: Computer simulation; Loads; Rolling; Storage tanks; Truck trailers; Vehicle dynamics
SAE Transaction: Vol. 98 (1989), Section(s) 2
Document Type: Technical Papers

Document Number: 892499

Title: Directional dynamics considerations for multi-articulated, multi- axled heavy vehicles
Publication Date: 1989
Author(s): Fancher, Paul S.
Organization(s): Transportation Research Institute, University of Michigan
Meeting: Truck and Bus Meeting and Exposition
Meeting Location: Charlotte, North Carolina, USA
Meeting Start Date: 6-Nov-89
Book containing this paper: SP-801
Index Terms: Truck trailers stability; Truck trailers handling; Tires; Truck dynamics; Truck cornering; Steering systems
SAE Transaction: Vol. 98 (1989), Section(s) 2
Document Type: Technical Papers

Document Number: 900843

Title: Low speed off tracking of multiple-axle road vehicles
Publication Date: 1990
Author(s): Mikulcik, E. C.; Jensen, L. G.
Organization(s): Dept. of Mech. Engrg., University of Calgary, Alberta, Canada; Dept. of Mech. Engrg., University of Calgary, Alberta, Canada
Meeting: SAE International Congress and Exposition
Meeting Location: Detroit, Michigan, USA
Meeting Start Date: 26-Feb-90
Index Terms: Axles; Steering; Truck tractors handling; Mathematical analysis; Tires; Truck trailers handling
SAE Transaction: Vol. 99 (1990), Section(s) 2
Document Type: Technical Papers

Document Number: 920050

Title: Variability in center of gravity height measurement
Publication Date: 1992

Author(s): Winkler, C. B.; Campbell, K. L.; Mink, C. E.
Organization(s): University of Michigan; University of Michigan; University of Michigan
Meeting: SAE International Congress and Exposition
Meeting Location: Detroit, Michigan, USA
Meeting Start Date: 24-Feb-92
Book containing this paper: SP-909
Index Terms: Statistical methods; Stiffness; Test facilities; Torque; Loads; Analysis of variance
SAE Transaction: Vol. 101 (1992), Section(s) 6
Document Type: Technical Papers

Document Number: 920582

Title: The measurement of static rollover metrics
Publication Date: 1992
Author(s): Chrstos, Jeffrey P.; Guenther, Dennis A.
Organization(s): Transportation Research Center of Ohio; Ohio State Univ.
Meeting: SAE International Congress and Exposition
Meeting Location: Detroit, Michigan, USA
Meeting Start Date: 24-Feb-92
Book containing this paper: SP-909
Index Terms: Roll over; Stability; Truck dynamics; Simulation
SAE Transaction: Vol. 101 (1992), Section(s) 6
Document Type: Technical Papers

Document Number: 921440

Title: Optimization of the steering and braking performance of commercial vehicles using electronic intelligence
Publication Date: Oct-92
Author(s): Göhring, Ernst; von Glasner, Egon-Christian; Povel, Rolf
Organization(s): Mercedes-Benz AG; Mercedes-Benz AG; Mercedes-Benz AG
Meeting: Mobility Technology Conferences and Exhibit
Meeting Location: Sao Paulo, Brasil
Meeting Start Date: 13-Oct-92
Index Terms: Braking; Steering; Electronic brake control; Automobile safety; Antiskid devices
Document Type: Technical Papers

Document Number: 922426

Title: Roll-stability performance of heavy-vehicle suspensions
Publication Date: 1992
Author(s): Winkler, C. B.; Karamihas, S. M.; Bogard, S. E.
Organization(s): University of Michigan Transportation Research Institute; University of Michigan Transportation Research Institute; University of Michigan Transportation Research Institute
Meeting: International Truck and Bus Meeting and Exposition
Meeting Location: Toledo, Ohio, USA
Meeting Start Date: 16-Nov-92
Book containing this paper: SP-940
Index Terms: Truck handling; Truck stability; Suspension systems; Truck design
SAE Transaction: Vol. 101 (1992), Section(s) 2
Document Type: Technical Papers

Document Number: 922442
Title: Evaluation of braking strategies on downgrades
Publication Date: 1992
Author(s): Fancher, Paul S.; Flick, Mark A.
Organization(s): University of Michigan Transportation Research Institute; National Highway Traffic Safety Administration
Meeting: International Truck and Bus Meeting and Exposition
Meeting Location: Toledo, Ohio, USA
Meeting Start Dat: 16-Nov-92
Index Terms: Truck safety; Truck design; Brakes; Pulsation
SAE Transaction: Vol. 101 (1992), Section(s) 2
Document Type: Technical Papers

Document Number: 922484
Title: MVMA/NHTSA/SAE heavy truck round robin brake test
Publication Date: 1992
Author(s): Kempf, Richard C.
Organization(s): Transportation Research Center Inc.
Meeting: International Truck and Bus Meeting and Exposition
Meeting Location: Toledo, Ohio, USA
Meeting Start Dat: 16-Nov-92
Index Terms: Antiskid devices; Friction; Surfaces; Truck safety; Stopping distances; Tests
SAE Transaction: Vol. 101 (1992), Section(s) 2
Document Type: Technical Papers

Document Number: 930832
Title: Repeatability of the tilt-table test method
Publication Date: Mar-93
Author(s): Winkler, C. B.; Bogard, S. E.; Campbell, K. E.
Organization(s): University of Michigan Transportation Research Institute; University of Michigan Transportation Research Institute; University of Michigan Transportation Research Institute
Meeting: SAE International Congress and Exposition
Meeting Location: Detroit, Michigan, USA
Meeting Start Date: 1-Mar-93
Book containing this paper: SP-950
Index Terms: Truck stability; Test equipment; Tires; Speed; Stiffness; Friction
SAE Transaction: Vol. 102 (1993), Section(s) 6
Document Type: Technical Papers

Document Number: 931878
Title: An advanced braking and stability controller for tow-vehicle and trailer combinations
Publication Date: Nov-93
Author(s): Elwell, Mark; Kimbrough, Scott
Organization(s): University of Utah; University of Utah
Meeting: International Pacific Conference on Automotive Engineering and High Temperature Engineering Conference
Meeting Location: Phoenix, Arizona, USA
Meeting Start Dat: 15-Nov-93

Index Terms: Antiskid devices; Braking; Stability; Trailers; Truck tractors; Truck tractors stability
SAE Transaction: Vol. 102 (1993), Section(s) 2
Document Type: Technical Papers

Document Number: 932949

Title: Estimation of dynamic rollover threshold of commercial vehicles using low speed experimental data
Publication Date: Nov-93
Author(s): Das, Niladri S.; Suresh, Bangalore A.; Wambold, James C.
Organization(s): Engineering Global Solutions Inc.; Pennsylvania Transportation Institute; Pennsylvania Transportation Institute
Meeting: SAE International Truck and Bus Meeting and Exposition
Meeting Location: Detroit, Michigan, USA
Meeting Start Date: 1-Nov-93
Book containing this paper SP-1002
Index Terms: Vehicle dynamics; Roll over; Computer simulation; Vehicle directional control; Bus handling
SAE Transaction: Vol. 102 (1993), Section(s) 2
Document Type: Technical Papers

Document Number: 932995

Title: Simple predictors of the performance of A-trains
Publication Date: Nov-93
Author(s): Winkler, C. B.; Bogard, S. E.
Organization(s): University of Michigan; University of Michigan
Meeting: SAE International Truck and Bus Meeting and Exposition
Meeting Location: Detroit, Michigan, USA
Meeting Start Date: 1-Nov-93
Book containing this paper SP-1002
Index Terms: Truck trailers handling; Roll over; Offtracking; Yaw
SAE Transaction: Vol. 102 (1993), Section(s) 2
Document Type: Technical Papers

Document Number: 940175

Title: Requirements for vehicle dynamics simulation models
Publication Date: Feb-94
Author(s): Allen, R. Wade; Rosenthal, Theodore J.
Organization(s): Systems Technology, Inc.; Systems Technology, Inc.
Meeting: SAE International Congress and Exposition
Meeting Location: Detroit, Michigan, USA
Meeting Start Date: 28-Feb-94
Index Terms: Computer applications; Computer modelling; Computer simulation; Models; Vehicle dynamics
Document Type: Technical Papers

Document Number: 950313

Title: The effects of tire cornering stiffness on vehicle linear handling performance
Publication Date: Feb-95

Author(s): Xia, X.; Willis, J. N.
Organization(s): General Tire, Inc.; General Tire, Inc.
Meeting: SAE International Congress and Exposition
Meeting Location: Detroit, Michigan, USA
Meeting Start Date: 27-Feb-95
Book containing this paper: SP-1074
Index Terms: Vehicle handling; Cornering; Steering
SAE Transaction: Vol. 104 (1995), Section(s) 6
Document Type: Technical Papers

Document Number: 952303

Title: Current positions and development trends in air brake systems for Mercedes-Benz commercial vehicles
Publication Date: Oct-95
Author(s): Marwitz, H.; Junghans, H.; Fischer, J.
Organization(s): Mercedes-Benz AG.; Mercedes-Benz AG.; Mercedes-Benz AG.
Meeting: SAE Brazil 95
Meeting Location: Sao Paulo, Brazil
Meeting Start Date: 2-Oct-95
Index Terms: Air brakes; Electronic brake control; Antiskid devices
Document Type: Technical Papers

Document Number: 952637

Title: Computer-based analysis of the dynamic performance of log hauling trucks
Publication Date: Nov-95
Author(s): Tong, X.; Tabarrok, B.; El-Gindy, M.
Organization(s): University of Victoria; University of Victoria; National Research Council Canada
Meeting: SAE International Truck and Bus Meeting and Exposition
Meeting Location: Winston-Salem, North Carolina, USA
Meeting Start Date: 13-Nov-95
Book containing this paper: SP-1128
Index Terms: Performance; Dynamics; Trucks; Mathematical models; Yaw; Logging equipment
SAE Transaction: Vol. 104 (1995), Section(s) 2
Document Type: Technical Papers

Document Number: 952663

Title: American Automobile Manufacturers Association heavy truck brake tire test
Publication Date: Nov-95
Author(s): Kempf, Richard C.; Lyon, William; Trueman, W. Charles; Boyce, Richard; Brundt, Claude
Organization(s): Transportation Research Center Inc.; Transportation Research Center Inc.; PACCAR Technical Center; Goodyear Technical Center; Goodyear Technical Center
Meeting: SAE International Truck and Bus Meeting and Exposition
Meeting Location: Winston-Salem, North Carolina, USA
Meeting Start Date: 13-Nov-95
Index Terms: Tests; Tires; Brakes; Trucks; Stability; Performance
Document Type: Technical Papers

Document Number: 960173

Title: Modeling assumptions for realistic multibody simulations of the yaw and roll behavior of heavy trucks
Publication Date: Feb-96
Author(s): Sayers, Michael W.; Riley, Stephen M.
Organization(s): University of Michigan Transportation Research Institute; University of Michigan Transportation Research Institute
Meeting: SAE International Congress and Exposition
Meeting Location: Detroit, Michigan, USA
Meeting Start Date: 26-Feb-96
Book containing this paper SP-1141
Index Terms: Behavior; Yaw; Simulation; Trucks; Computer simulation; Roll over
SAE Transaction: Vol. 105 (1996), Section(s) 2
Document Type: Technical Papers

Document Number: 960176

Title: Verification of vehicle parameters for use in computer simulation
Publication Date: Feb-96
Author(s): Gruening, James; Bernard, James E.
Organization(s): Iowa State Univ.; Iowa State Univ.
Meeting: SAE International Congress and Exposition
Meeting Location: Detroit, Michigan, USA
Meeting Start Date: 26-Feb-96
Book containing this paper SP-1141
Index Terms: Computer simulation; Data acquisition; Parameters; Performance metrics; Simulation; Vehicle dynamics
Document Type: Technical Papers

Document Number: 960184

Title: Lateral/directional stability of tow dolly type combination vehicles
Publication Date: Feb-96
Author(s): Klein, Richard H.; Teper, Gary L.; Fait, James D.
Organization(s): Consultant; Consultant; U-Haul International
Meeting: SAE International Congress and Exposition
Meeting Location: Detroit, Michigan, USA
Meeting Start Date: 26-Feb-96
Book containing this paper SP-1141
Index Terms: Stability; Towing; Towing devices; Computer programs; Yaw; Stiffness
SAE Transaction: Vol. 105 (1996), Section(s) 6
Document Type: Technical Papers

Document Number: 962153

Title: Truck tire wet traction: effects of water depth, speed, tread depth, inflation, and load
Publication Date: Oct-96
Author(s): Pottinger, Marion G.; Pelz, Wolfgang; Pottinger, Derek M.; Winkler, Christopher B.
Organization(s): Smithers Scientific Services, Inc.; University of Akron; Alatheia Data Analysis; University of Michigan Transportation Research Institute
Meeting: 1996 SAE International Truck and Bus Meeting and Exposition

Meeting Location: Detroit, Michigan, USA
Meeting Start Date: 14-Oct-96
Book containing this paper SP-1201
Index Terms: Tire road interface; Traction; Water; Truck cornering
SAE Transaction: Vol. 105 (1996), Section(s) 2
Document Type: Technical Papers

Document Number: 962195

Title: Advanced collision avoidance demonstration for heavy-duty vehicles
Publication Date: Oct-96
Author(s): Chakraborty, Shubhayu; Gee, Thomas A.; Smedley, Dan
Organization(s): Eaton Corp.; Eaton Corp.; Eaton Corp.
Meeting: 1996 SAE International Truck and Bus Meeting and Exposition
Meeting Location: Detroit, Michigan, USA
Meeting Start Date: 14-Oct-96
Index Terms: Collision avoidance systems; Electronic brake control; Trucks
SAE Transaction: Vol. 105 (1996), Section(s) 2
Document Type: Technical Papers

Document Number: 970560

Title: Variable dynamic testbed vehicle: dynamics analysis
Publication Date: Feb-97
Author(s): Lee, Allan Y.; Le, Nhan T.; Marriott, Alan T.
Organization(s): California Institute of Technology; University of California; Jet Propulsion Laboratory
Meeting: SAE International Congress and Exposition
Meeting Location: Detroit, Michigan, USA
Meeting Start Date: 24-Feb-97
Book containing this paper SP-1228
Index Terms: Dynamics; Accident avoidance; Collision avoidance systems; Vehicle dynamics; Simulation; Sensitivity analysis
Document Type: Technical Papers

Document Number: 970966

Title: Heavy truck wheel load distributions on the highway
Publication Date: Feb-97
Author(s): Kinney, J. Rolly; Munsee, Craig L.
Organization(s): Kinney Engineering, Inc.; AFI Associates, Inc.
Meeting: SAE International Congress and Exposition
Meeting Location: Detroit, Michigan, USA
Meeting Start Date: 24-Feb-97
Book containing this paper SP-1237
Index Terms: Loads; Highways; Trucks; Accidents; Roll over; Stability
Document Type: Technical Papers

Document Number: 971122

Title: Application of neural networks in the estimation of tire/road friction using the tire as sensor

Publication Date: Feb-97
Author(s): Pasterkamp, W. R.; Pacejka, H. B.
Organization(s): Delft University of Technology; Delft University of Technology
Meeting: SAE International Congress and Exposition
Meeting Location: Detroit, Michigan, USA
Meeting Start Date: 24-Feb-97
Book containing this paper SP-1228
Index Terms: Roads; Sensors; Tires; Friction; Behavior; Simulation
Document Type: Technical Papers

Document Number: 973188

Title: Determination of lateral axle data of heavy vehicle combinations
Publication Date: Nov-97
Author(s): Vlasgstedt, Nils-Gunnar; Dahlberg, Erik
Organization(s): Scania; The Royal Institute of Technology
Meeting: SAE International Truck and Bus Meeting and Exposition
Meeting Location: Cleveland, Ohio, USA
Meeting Start Date: 17-Nov-97
Book containing this paper SP-1308
Index Terms: Axles; Mathematical analysis; Vehicle directional control; Truck cornering; Truck stability
Document Type: Technical Papers

Document Number: 973190

Title: The correlation of heavy vehicle performance measures
Publication Date: Nov-97
Author(s): McFarlane, Scott; Sweatman, Peter; Dovile, Paul; Woodrooffe, John
Organization(s): Roaduser Research Pty. Ltd.; Roaduser Research Pty. Ltd.; Roaduser Research Pty. Ltd.; Roaduser Research Pty. Ltd.
Meeting: SAE International Truck and Bus Meeting and Exposition
Meeting Location: Cleveland, Ohio, USA
Meeting Start Date: 17-Nov-97
Book containing this paper SP-1308
Index Terms: Vehicle directional control; Truck stability; Vehicle dynamics
Document Type: Technical Papers

Document Number: 973264

Title: The advantages of a simple approach modeling heavy vehicle handling
Publication Date: Nov-97
Author(s): Dahlberg, Erik; Vlasgstedt, Nils-Gunnar
Organization(s): The Royal Institute of Technology; Scania
Meeting: SAE International Truck and Bus Meeting and Exposition
Meeting Location: Cleveland, Ohio, USA
Meeting Start Date: 17-Nov-97
Book containing this paper SP-1308
Index Terms: Mathematical models; Truck handling; Vehicle directional control; Truck stability
Document Type: Technical Papers

Document Number: 973268

Title: The development of high productivity combination vehicles using computer simulation

Publication Date: Nov-97

Author(s): McFarlane, Scott; Sweatman, Peter

Organization(s): Roaduser Research Pty. Ltd.; Roaduser Research Pty. Ltd.

Meeting: SAE International Truck and Bus Meeting and Exposition

Meeting Location: Cleveland, Ohio, USA

Meeting Start Date: 17-Nov-97

Book containing this paper SP-1308

Index Terms: Computer simulation; Road surfaces; Vehicle directional control; Towing

Document Type: Technical Papers

Document Number: 973282

Title: The compatibility of tractor/trailer combinations during braking maneuvers

Publication Date: Nov-97

Author(s): von Glasner, Egon-Christian; Pflug, Hans-Christian; Povel, Rolf; Wüst, Klaus

Organization(s): Daimler-Benz AG; Daimler-Benz AG; Daimler-Benz AG; Daimler-Benz AG

Meeting: SAE International Truck and Bus Meeting and Exposition

Meeting Location: Cleveland, Ohio, USA

Meeting Start Date: 17-Nov-97

Book containing this paper SP-1307

Index Terms: Electronic brake control; Braking; Truck handling; Vehicle directional control

Document Type: Technical Papers

Document Number: 973283

Title: EBS and tractor trailer brake compatibility

Publication Date: Nov-97

Author(s): Lindemann, Klaus; Petersen, Erwin; Schult, Manfred; Korn, Alan

Organization(s): WABCO Fahrzeugbremsen; WABCO Fahrzeugbremsen; WABCO Fahrzeugbremsen; Rockwell WABCO Vehicle Control Systems

Meeting: SAE International Truck and Bus Meeting and Exposition

Meeting Location: Cleveland, Ohio, USA

Meeting Start Date: 17-Nov-97

Book containing this paper SP-1307

Index Terms: Electronic brake control; Braking; Trailers

Document Type: Technical Papers

Document Number: 980372

Title: The trailer simulation model of PC-CRASH

Publication Date: Feb-98

Author(s): Steffan, Hermann; Moser, Andreas

Organization(s): Graz University of Technology; Graz University of Technology

Meeting: SAE International Congress and Exposition

Meeting Location: Detroit, Michigan, USA

Meeting Start Date: 23-Feb-98

Book containing this paper SP-1319

Index Terms: Models; Simulation; Trailers; Accidents; Trailer accidents; Accident reconstruction
Document Type: Technical Papers

Document Number: 980898

Title: The improvement of handling performances through the sensitivity analysis validated by the K&C test
Publication Date: Feb-98
Author(s): Sohn, Hee-Seong; Shin, Hyun-Woo; Lee, Hwa-Won
Organization(s): Hyundai Precision & Ind. Co.; Hyundai Precision & Ind. Co.; Hyundai Precision & Ind. Co.
Meeting: SAE International Congress and Exposition
Meeting Location: Detroit, Michigan, USA
Meeting Start Date: 23-Feb-98
Book containing this paper SP-1338
Index Terms: Vehicle handling; Performance; Sensitivity analysis; Parametric analysis; Computer aided design (CAD); Computer simulation
Document Type: Technical Papers\Document Number:

Document Number: 982746

Title: Example utilization of truck tire characteristics data in vehicle dynamics simulations
Publication Date: Nov-98
Author(s): Burke, Robert J.; Robertson, John D.; Sayers, Michael W.; Pottinger, Marion G.
Organization(s): Robertson & Robertson Consultants, Inc.; Robertson & Robertson Consultants, Inc.; Mechanical Simulation Corp.; Smithers Scientific Services, Inc.
Meeting: SAE International Truck and Bus Meeting and Exposition
Meeting Location: Indianapolis, Indiana, USA
Meeting Start Date: 16-Nov-98
Index Terms: Truck handling; Tires; Tire road interface; Computer modelling; Computer simulation
Document Type: Technical Papers

Document Number: 982748

Title: Force and moment properties of a small sample of tire specifications: Drive, steer, and trailer with evolution from new to naturally worn-out to retreaded considered
Publication Date: Nov-98
Author(s): Pottinger, Marion G.; Pelz, Wolfgang; Winkler, Christopher B.; Pottinger, Derek M.; Tapia, George A.
Organization(s): Smithers Scientific Services, Inc.; University of Akron; University of Michigan Transportation Research Institute; Smithers Scientific Services, Inc.; Calspan Corp.
Meeting: SAE International Truck and Bus Meeting and Exposition
Meeting Location: Indianapolis, Indiana, USA
Meeting Start Date: 16-Nov-98
Index Terms: Truck handling; Tires; Tire road interface; Test methods; Braking; Specifications
Document Type: Technical Papers

Document Number: 982819

Title: Vehicle stability and control research for U.S. comprehensive truck size and weight (TS&W) study
Publication Date: Nov-98

Author(s): Blow, Philp W.; Woodrooffe, John H.; Sweatman, Peter F.
Organization(s): Federal Highway Administration; Roaduser Research International; Roaduser Research International
Meeting: SAE International Truck and Bus Meeting and Exposition
Meeting Location: Indianapolis, Indiana, USA
Meeting Start Date: 16-Nov-98
Book containing this paper SP-1400
Index Terms: Trucks; Truck safety; Truck stability; Roll over
Document Type: Technical Papers

Document Number: 982821

Title: Truck size and weight practice in Canada~The engineering approach
Publication Date: Nov-98
Author(s): Woodrooffe, John H. F.
Organization(s): Roaduser Research International
Meeting: SAE International Truck and Bus Meeting and Exposition
Meeting Location: Indianapolis, Indiana, USA
Meeting Start Date: 16-Nov-98
Index Terms: Trucks; Truck safety; Truck stability; Roll over; Loads
Document Type: Technical Papers

Document Number: 982823

Title: The potential for performance-based standards as the basis for truck size and weight regulations in the United States
Publication Date: Nov-98
Author(s): York, James S.; Maze, Tom
Organization(s): National Private Truck Council; Center for Transportation Research and Education
Meeting: SAE International Truck and Bus Meeting and Exposition
Meeting Location: Indianapolis, Indiana, USA
Meeting Start Date: 16-Nov-98
Index Terms: Trucks; Regulations; Axles; Roads
Document Type: Technical Papers

Document Number: 1999-01-0030

Title: Understanding vehicle roll using mechanism simulation software
Publication Date: Mar-99
Author(s): Jones, Robert A.
Organization(s): Ford Motor Co.
Meeting: SAE International Congress and Exposition
Meeting Location: Detroit, Michigan, USA
Meeting Start Date: 1-Mar-99
Book containing this paper SP-1438
Index Terms: Steering; Roll over; Computer simulation; Suspension performance; Vehicle dynamics
Document Type: Technical Papers

Document Number: 1999-01-1301

Title: Intelligent systems for aiding the truck driver in vehicle control

Publication Date: Mar-99
 Author(s): Winkler, C.; Fancher, P.; Ervin, R.
 Organization(s): The University of Michigan Transportation Research Institute; The University of Michigan Transportation Research Institute; The University of Michigan Transportation Research Institute
 Meeting: SAE International Congress and Exposition
 Meeting Location: Detroit, Michigan, USA
 Meeting Start Date: 1-Mar-99
 Book containing this paper SP-1428
 Index Terms: Truck safety; Truck stability; Truck operation; Roll over; Truck trailers handling; Truck trailers stability
 Document Type: Technical Papers

Document Number: 1999-01-2952

Title: Yaw instability due to longitudinal load transfer during braking in a curve
 Publication Date: Aug-99
 Status: Current
 Author(s): Dahlberg, Erik
 Organization(s): Royal Institute of Technology
 Meeting: Future Transportation Technology Conference
 Meeting Location: Costa Mesa, California, USA
 Meeting Start Date: 17-Aug-99
 Book containing this paper SP-1467
 Index Terms: Braking; Steering; Vehicle dynamics; Yaw
 Document Type: Technical Papers

8.2.1.2 *Automotive Engineering* articles

Document Number: 3-101-5-5

Title: Roll stability of suspensions
 Publication Date: May-93
 Author(s): Winkler, C. B.; Karamihas, S. M.; Bogard, S. E.
 Organization(s): University of Michigan Transportation Research Institute; University of Michigan Transportation Research Institute; University of Michigan Transportation Research Institute
 Index Terms: Truck handling; Truck stability; Stiffness; Suspension systems; Measurement; Mathematical analysis
 Source: Truck Engineering (Supplement to Automotive Engineering, ISSN 0098-2571, Vol. 101, No. 5), p. 5 (5
 Section: Article
 Document Type: Journals

Document Number: 3-104-11-7

Title: Heavy truck load distributions
 Publication Date: Nov-97
 Index Terms: Engineering; Trucks; Weight; Loads; Stability; Roll over
 Source: Truck Engineering (Supplement to Automotive Engineering, ISSN 0098-2571, Vol. 104, No. 11), p. 7 (3 pp.)
 Section: Article
 Document Type: Journals

8.2.1.3 Society of Automotive Engineers standards

Document Number: SAE J 2179

Title: A Test for Evaluating the Rearward Amplication of multi-Articulated vehicles
Publication Date: Sep-93
Status: Current
Index Terms: Off-tracking; Rearward amplication; Truck trailers--Multiple articulation; Trucks and buses--Multiple articulation
Other number: J2179
Source: Handbook 3:36.56
Information Group: RECOMMENDED PRACTICE
Cross Reference(s) FMVSS 105; SAE J 2180; FMVSS 121
Document Type: Standards

Document Number: SAE J 2180

Title: A Tilt Table Procedure for Measuring the Static Rollover Threshold for Heavy Trucks
Publication Date: Dec-98
Status: Current
Index Terms: Rollover thresholds; Simulation; Tilt table; Trucks and buses--Rollover threshold
Other number: J2180
Source: Handbook 2:23.712
Information Group: RECOMMENDED PRACTICE
Cross Reference(s) 800906; UMTRI-87-31; 881869
Document Type: Standards

Document Number: SAE J 1626

Title: Braking, Stability, and Control Performance Test Procedures for Air-Brake- Equipped Trucks
Publication Date: Apr-96
Status: Current
Index Terms: Air brakes; Brakes--Trucks and buses; Road tests; Service brakes; Stability--Trucks and buses; Stopping distance; Performance testing--Brakes; Trucks and buses--Brakes
Other number: J1626
Source: Handbook 3:36.127
Information Group: RECOMMENDED PRACTICE
Cross Reference(s) ASTM E 1136; FMVSS 121; ASTM E 1337
Document Type: Standards

8.2.2 References by parameter or performance measure

	1999-01-1301	SAE-310155	SAE-730182	SAE-740136	SAE-750398	SAE-760025	SAE-800905
tire properties							
cornering stiffness							
longitudinal slip							
aligning stiffness							
friction coefficient							
treadwear							
mass properties							
vehicle mass			•				
moment of inertia							
center of gravity			•				
axle mass							
axle moment of inertia							
steering							
Ackerman geometry							
steering ratio							
toe							
camber						•	
caster						•	
tandem skew							
suspension							
roll center height							
roll stiffness		•	•	•			•
ride stiffness			•	•			•
configuration							
number of axles							
size and weight							
wheelbase							
braking							
efficiency					•		
stability						•	
stopping distance							
friction demand							
friction utilization							
time delay							
handling							
yaw damping							
understeer/oversteer							
stability							
operating conditions							
load distribution							
rollover propensity							
static rollover threshold							
load transfer ratio							
rollover stability	•	•					
off tracking							
steady state							
transient							
high speed							
low speed							
trailing fidelity							

	SAE-800906	SAE-821259	SAE-850537	SAE-852333	SAE-852334	SAE-852335	SAE-861975
tire properties							
cornering stiffness							
longitudinal slip							
aligning stiffness							
friction coefficient							
treadwear							
mass properties							
vehicle mass							
moment of inertia							
center of gravity							
axle mass							
axle moment of inertia							
steering							
Ackerman geometry							•
steering ratio							
toe							
camber							
caster							
tandem skew							
suspension							
roll center height							
roll stiffness	•						
ride stiffness	•						
configuration							
number of axles							
size and weight							
wheelbase							
braking							
efficiency							
stability							
stopping distance							
friction demand							
friction utilization							
time delay							
handling							
yaw damping							
understeer/oversteer			•			•	
stability							
operating conditions							
load distribution							
rollover propensity							
static rollover threshold							
load transfer ratio							
rollover stability							
off tracking							
steady state							
transient							
high speed							
low speed				•	•		
trailing fidelity							
rearward amplification		•					

	SAE-870334	SAE-870494	SAE-892499	SAE-900843	SAE-920050	SAE-922426	SAE-932949
tire properties							
cornering stiffness			•				
longitudinal slip							
aligning stiffness							
friction coefficient							
treadwear							
mass properties							
vehicle mass					•		
moment of inertia							
center of gravity							
axle mass							
axle moment of inertia							
steering							
Ackerman geometry							
steering ratio							
toe							
camber							
caster							
tandem skew							
suspension							
roll center height						•	
roll stiffness						•	
ride stiffness							
configuration							
number of axles			•				
size and weight			•				
wheelbase							
braking							
efficiency	•	•					
stability							
stopping distance							
friction demand							
friction utilization							
time delay							
handling							
yaw damping							
understeer/oversteer							
stability							
operating conditions							
load distribution							
rollover propensity							
static rollover threshold		•					
load transfer ratio							
rollover stability						•	•
off tracking							
steady state							
transient		•					
high speed		•					
low speed				•			
trailing fidelity							
rearward amplification		•					

	SAE-932993	SAE-932995	SAE-933046	SAE-952637	SAE-960173	SAE-970966	SAE-973188
tire properties							
cornering stiffness							
longitudinal slip							
aligning stiffness							
friction coefficient							
treadwear							
mass properties							
vehicle mass							
moment of inertia							
center of gravity							
axle mass							
axle moment of inertia							
steering							
Ackerman geometry							
steering ratio							
toe			•				
camber			•				
caster			•				
tandem skew			•				
suspension							
roll center height							
roll stiffness							
ride stiffness							
configuration							
number of axles	•					•	
size and weight	•					•	
wheelbase	•						
braking							
efficiency							
stability							
stopping distance							
friction demand	•			•			
friction utilization							
time delay							
handling							
yaw damping		•					
understeer/oversteer	•			•			•
stability							
operating conditions							
load distribution						•	
rollover propensity							
static rollover threshold	•	•		•			
load transfer ratio	•	•		•			
rollover stability					•		
off tracking							
steady state							
transient	•	•		•			
high speed	•	•		•			
low speed							
trailing fidelity							
rearward amplification		•		•			

	SAE-973264	SAE-973268	SAE-973282	SAE-982743	SAE-982747
tire properties					
cornering stiffness				•	•
longitudinal slip				•	•
aligning stiffness				•	
friction coefficient				•	
treadwear					
mass properties					
vehicle mass					
moment of inertia					
center of gravity					
axle mass					
axle moment of inertia					
steering					
Ackerman geometry					
steering ratio					
toe					
camber					
caster					
tandem skew					
suspension					
roll center height					
roll stiffness					
ride stiffness					
configuration					
number of axles					
size and weight					
wheelbase					
braking					
efficiency					
stability			•		
stopping distance					
friction demand					
friction utilization					
time delay					
handling					
yaw damping	•				
understeer/oversteer					
stability					
operating conditions					
load distribution					
rollover propensity					
static rollover threshold					
load transfer ratio					
rollover stability					
off tracking					
steady state					
transient					
high speed					
low speed					
trailing fidelity		•			
rearward amplification					

8.3 PATH experimental heavy vehicle

8.3.1 Steering system dimensions top view (millimeters)

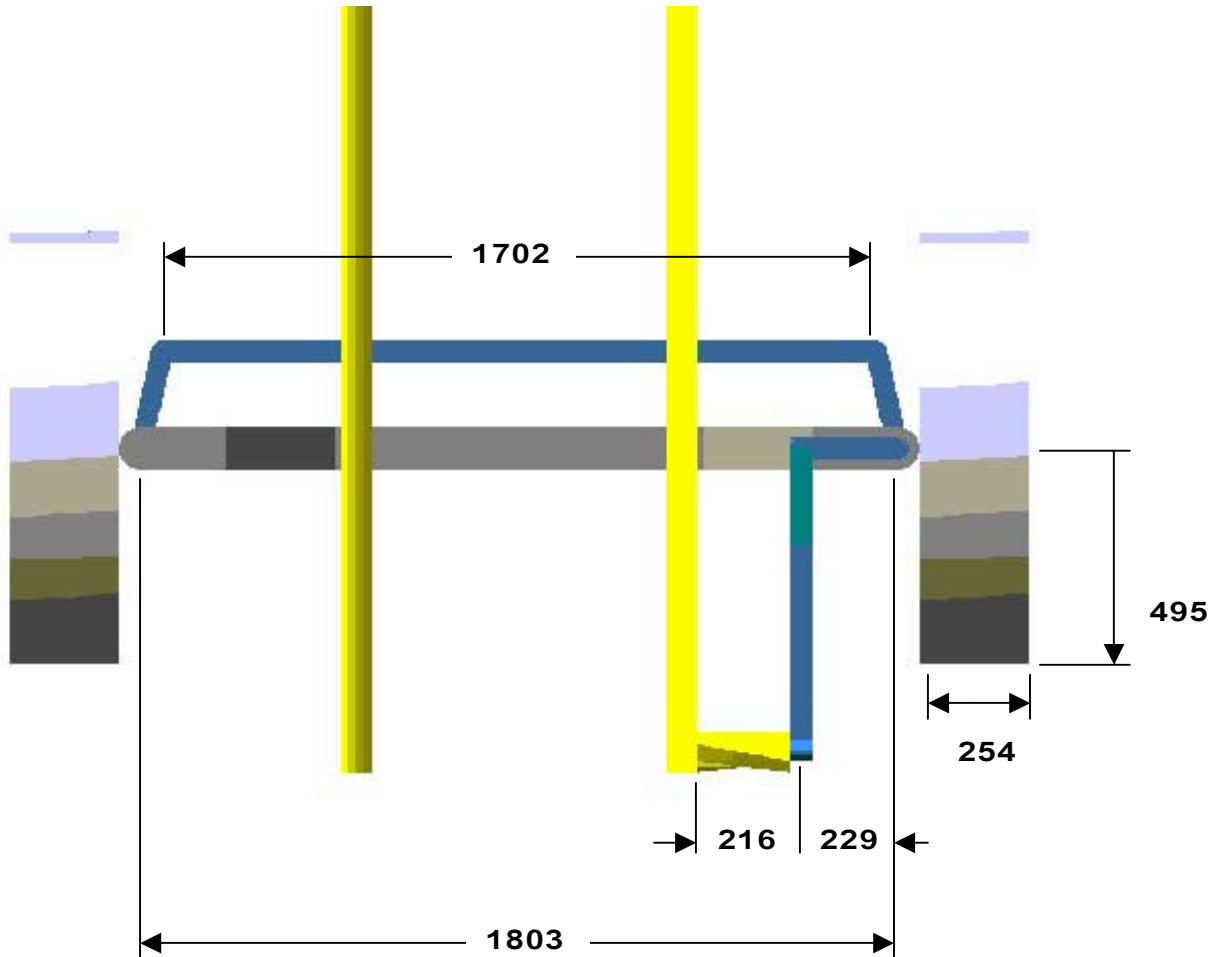

8.3.2 Steering system dimensions side view (millimeters)

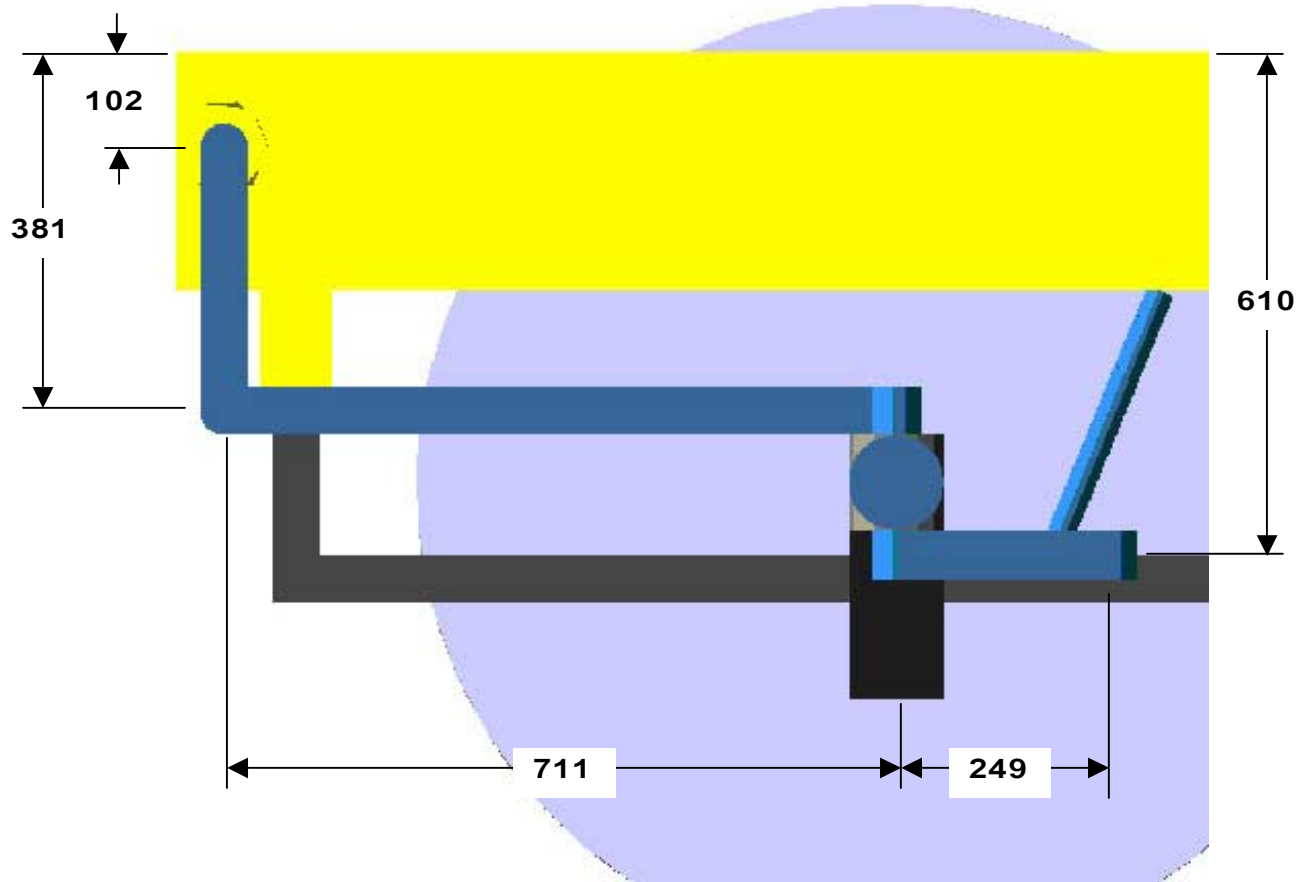

8.3.3 Front suspension dimensions side view (millimeters)

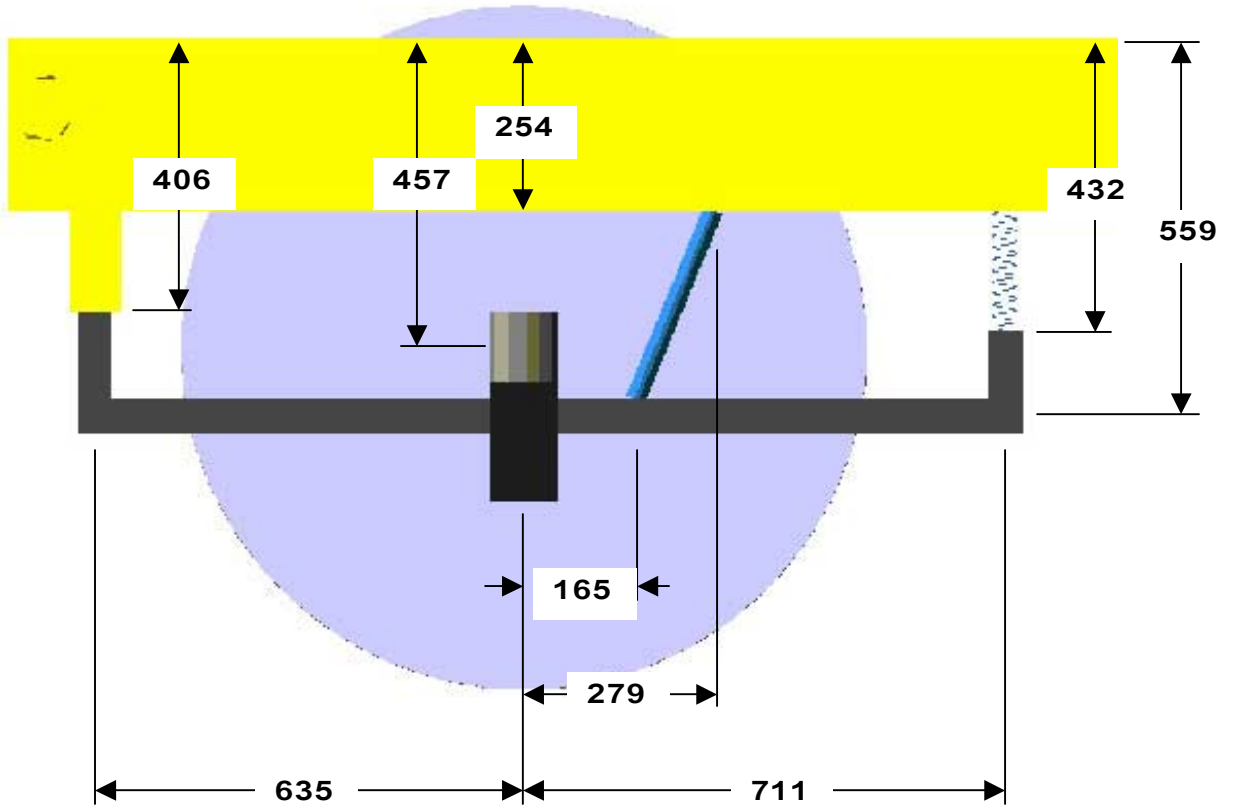

8.3.4 Rear suspension dimensions side view (millimeters)

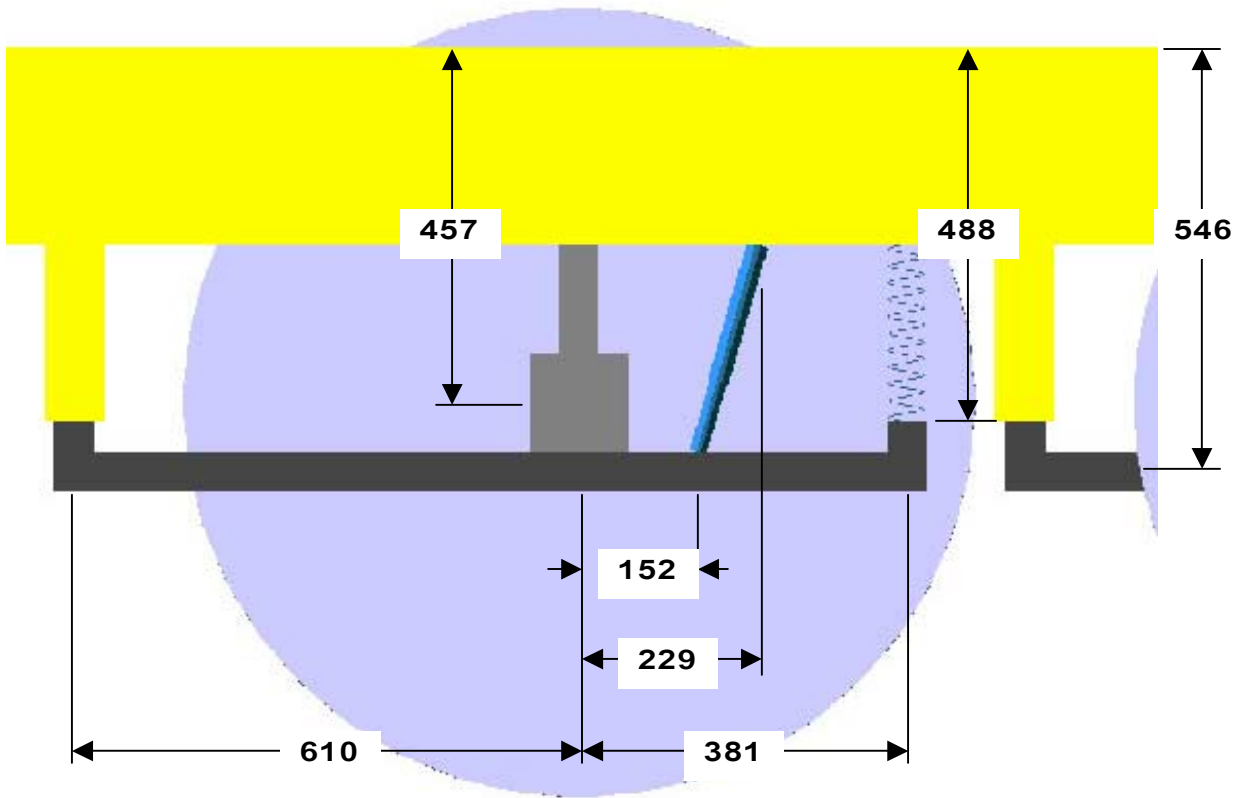

8.3.5 Trailer suspension dimensions side view (millimeters)

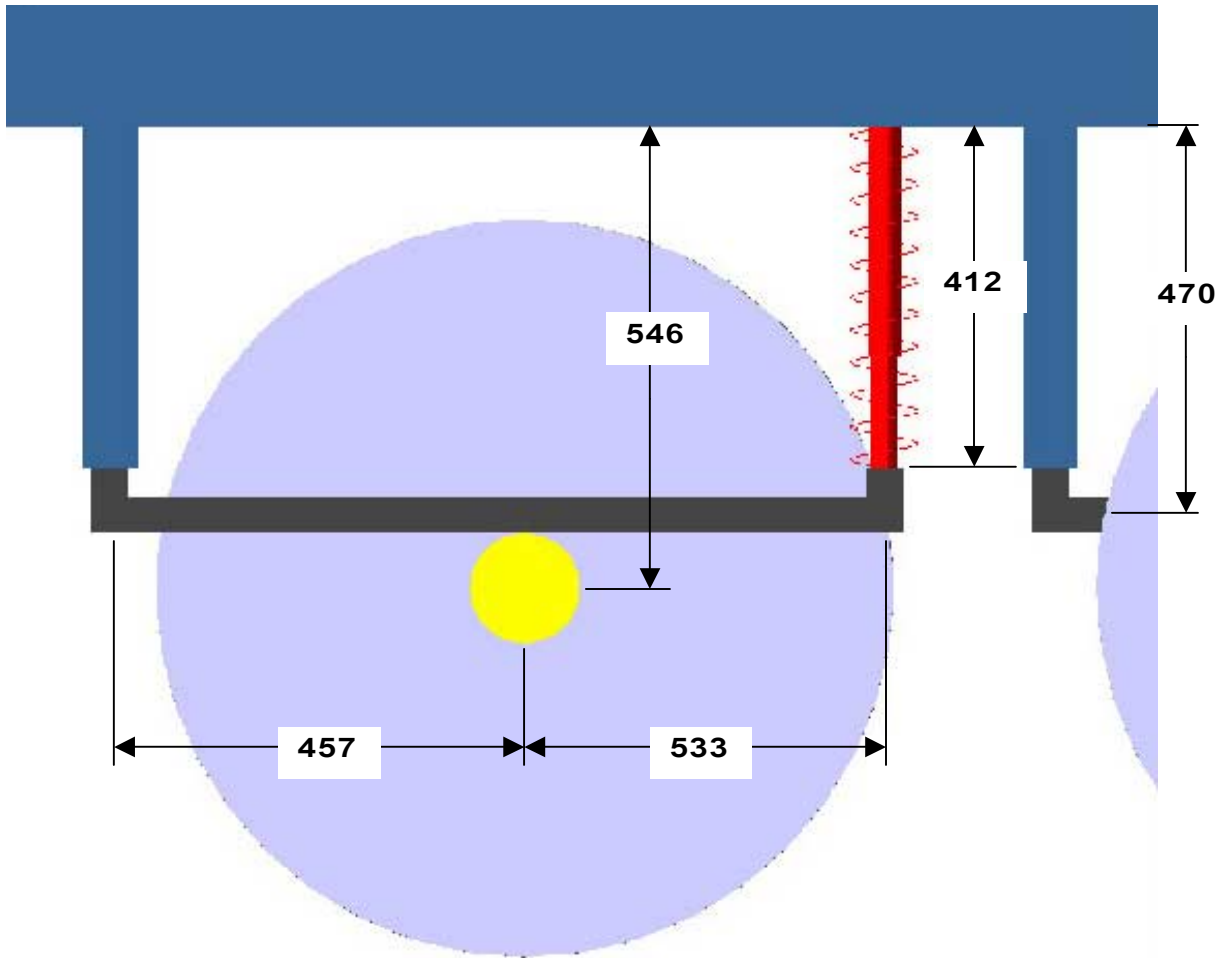

8.3.6 Track rod dimensions rear view (millimeters)

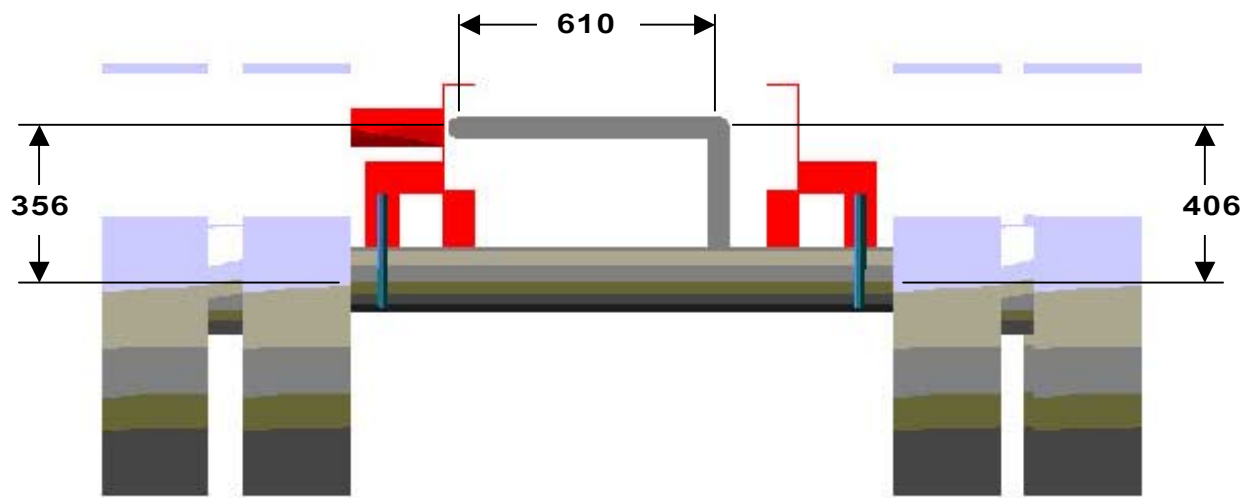

8.3.7 Tractor dimensions (millimeters)

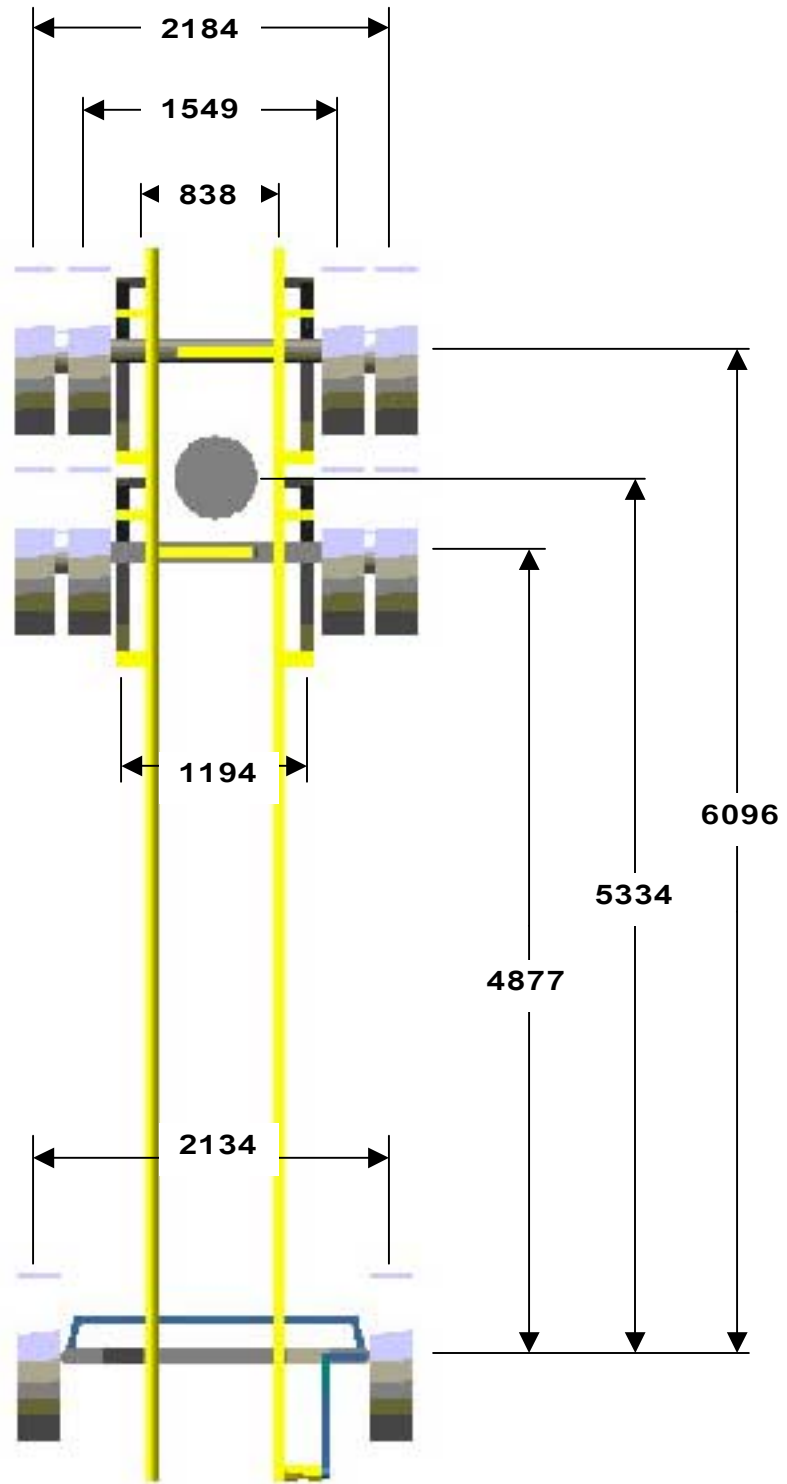

8.3.8 Semitrailer dimensions (millimeters)

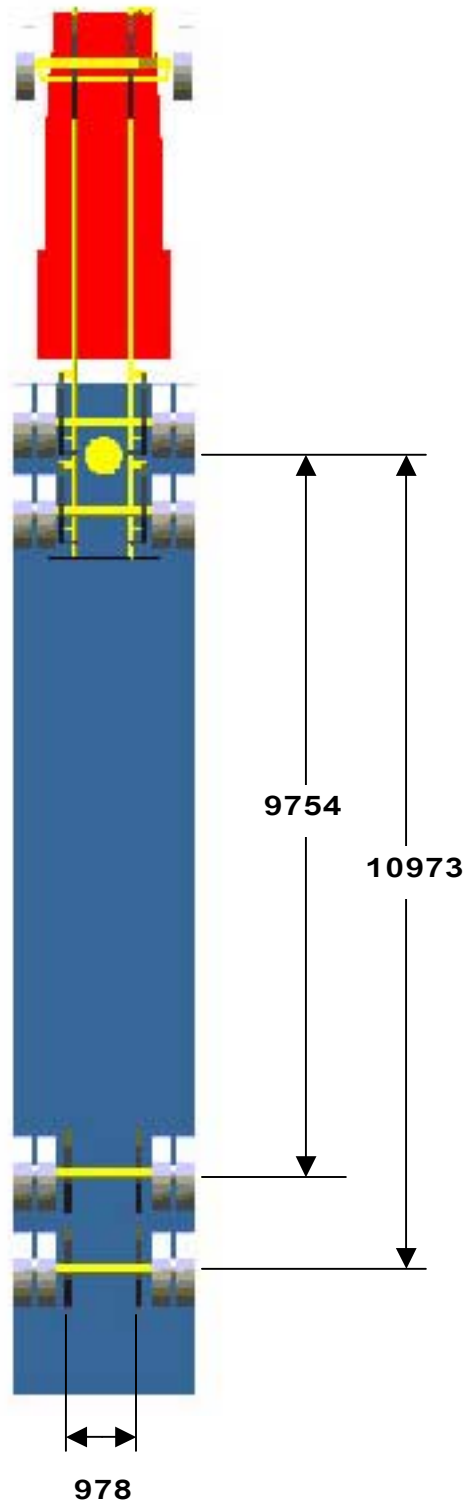

8.3.9 Weights and moments of inertia from [16]

	Weight (lbs)	I_{xx} (in lb sec ²)	I_{yy} (in lb sec ²)	I_{zz} (in lb sec ²)
Tractor	19420	80800	381800	372200
Tire and wheel	201	61	107	61
Steer axle	210	292	6	292
Dual tire and wheel	402	158	225	158
Front drive axle	843	636	197	636
Rear drive axle	775	691	79	691
Semitrailer (empty)	12469	85310	1468000	1546000
Semitrailer axle	437	763	29	763

8.3.10 Suspension parameters from [16]

Steer axle				
<i>At a nominal suspension load of:</i>		<i>10000 lbs</i>	<i>25000 lbs</i>	<i>40000 lbs</i>
Vertical stiffness (lb/in)		1230	1340	1390
Total roll stiffness (in lb/deg)		21900	21300	22200
Coulomb damping (lbs)		315	330	330
Leading drive axle				
<i>At a nominal suspension load of:</i>		<i>16000 lbs</i>	<i>28000 lbs</i>	<i>40000 lbs</i>
Vertical stiffness (lb/in)		3120	4510	6110
Total roll stiffness (in lb/deg) ¹		56000	76200	96400
Total roll stiffness (in lb/deg) ²		56000	68200	79700
Coulomb damping (lbs)		720	940	1120
Trailing drive axle				
<i>At a nominal suspension load of:</i>		<i>16000 lbs</i>	<i>28000 lbs</i>	<i>40000 lbs</i>
Vertical stiffness (lb/in)		3740	5550	6800
Total roll stiffness (in lb/deg) ¹		57900	87400	95700
Total roll stiffness (in lb/deg) ²		57900	67500	64900
Coulomb damping (lbs)		855	1480	1950
Leading trailer axle				
<i>At a nominal suspension load of:</i>		<i>10000 lbs</i>	<i>25000 lbs</i>	<i>40000 lbs</i>
Vertical stiffness (lb/in)		7720	10100	11500
Total roll stiffness (in lb/deg)		143500	175000	245000
Coulomb damping (lbs)		380	1075	-
Trailing trailer axle				
<i>At a nominal suspension load of:</i>		<i>10000 lbs</i>	<i>25000 lbs</i>	<i>40000 lbs</i>
Vertical stiffness (lb/in)		6520	8990	16000
Total roll stiffness (in lb/deg)		126000	178000	245000
Coulomb damping (lbs)		260	808	-

¹ For roll angles less than 1 degree.

² For roll angles greater than 2 degrees.