

## Feeling is Believing: Using a Force-Feedback Joystick to Teach Dynamic Systems

Christopher Richard, Allison M. Okamura, Mark R. Cutkosky  
Center for Design Research, Stanford University

### Abstract

As an innovative approach to teaching the laboratory component of an undergraduate course on dynamic systems, we present the haptic paddle: a low-cost, single-axis, force-feedback joystick. Using the paddle, students not only learned to model and analyze dynamic systems, but by using their sense of touch, they were able to feel the effects of phenomena such as viscous damping, stiffness, and inertia. Feeling the dynamics, in addition to learning the underlying physics, improved students' understanding and added an element of fun to the course. In this paper, we describe the purpose and design of the haptic paddle, present examples of how the paddle was integrated into laboratory exercises, and show the results of student evaluations.

### 1. Introduction

Engineering educators are continually challenged to provide physical examples in order to make course material more interesting and accessible to students. Laboratory exercises, software simulations, and in-class demonstrations are all helpful in developing students' ability to connect theoretical principles with physical reality. The literature contains several examples of computer-based dynamic simulations being used for pedagogical purposes<sup>1,4,9</sup>. But even with these aids, concepts such as eigenvalues, instability, and time constants can seem mysterious to students encountering them for the first time. Haptic interfaces, which allow a user to feel a virtual environment, are promising tools for helping students obtain an understanding of these physical phenomena.

#### 1.1 The Field of Haptics

The word *haptic* means relating to or based on the sense of touch. It can refer to a human or robot's ability to sense the world via touch, or the display of a virtual environment through touch. Words often associated with this concept are *haptic display*, *force feedback*, and *force reflection*. All of these are technologies that allow computers to convey realistic physical sensations to users<sup>2</sup>. Similar to graphic displays, haptic displays are a useful way of portraying many different kinds of information. Haptic displays take on many forms, depending on the degrees of freedom of sensing and actuation. Many displays are currently available in a (two degree-of-freedom) joystick configuration, for use with entertainment applications such as video games.

Most haptic feedback systems consist of a virtual environment stored in a computer, a haptic device or interface, and the user, as shown in Figure 1. The virtual environment contains information about the magnitude and direction of forces to be applied to the user, usually depending on the position and velocity of a cursor in the environment. When the user moves the joystick, the position of the cursor changes, allowing for dynamic interactions with the virtual environment. The information about the position, as well as the force to be displayed, usually has an update rate of at least 500 Hz for smooth haptic display.

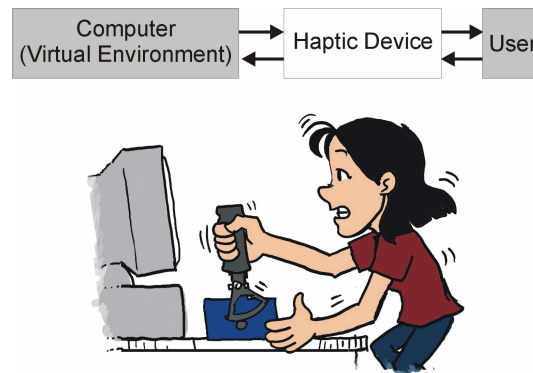

Figure 1. Components of a haptic display system.

## 1.2 Educational Applications

Although haptic display technology has existed for decades, it is only recently that the necessary computing speed and hardware have become economically feasible for use in education. Even so, many of the current systems used in educational applications are still quite expensive, complex, and vocationally focused. Two examples are flight and medical training<sup>6</sup>. Military and commercial pilots may now be trained in flight simulators, which apply forces on the controls corresponding to those occurring during actual flight. Many types of medical simulation haptic interfaces exist, particularly for laproscopic and endoscopic surgery. The virtual environments for this application are programmed to be similar to the soft tissue inside the human body; the user can practice removing polyps, suturing, etc.

The haptic displays used in such applications are certainly more complex and expensive than what is required for demonstrating the types of physical principles usually communicated in the undergraduate engineering curriculum. Some of the phenomena that might be well-illustrated using force feedback include curves and surfaces, gravitational forces between planets, magnetic fields, dynamic systems, and the effects of control laws. Other than the haptic paddle presented in this paper and similar projects inspired by it, we have not seen haptics used to illustrate physical principles in undergraduate or K-12 education. Some haptics is used at the graduate level, but primarily as part of a robotics courses as a general research topic.

### 1.3 The Haptic Paddle

The idea for developing the haptic paddle began with the success of in-class demonstrations of commercial human/computer interaction products. The authors were inspired that students were excited by the “high-tech” subject, and knew from previous efforts to develop “haptic video games” that the combination for force feedback and computer graphics could create a compelling sense of physical interaction with objects in a computer simulation<sup>5</sup>. Also, we knew that the haptic interfaces currently available on the market were far too expensive to provide enough devices for a large undergraduate class.

Motivated by these considerations, we designed simple single-axis haptic interface kits that students could assemble, model, connect to a computer, and use for interacting with computer simulations of dynamic systems. The students were enrolled in a ten-week course on Dynamic Systems, a part of the undergraduate sequence in Mechanical Engineering at Stanford University. The enrollment in the course is approximately 60 students, and the students work in groups of 3 or 4, requiring at least 15 haptic paddle kits. The haptic paddles have now been used for three years in this course and both the design of the devices and software, as well as the way they are used in the course, have undergone continual refinement.

In this paper, we first describe the haptic paddle and highlight the primary challenges in designing a low-cost haptic device. Next, we provide a detailed account of how the haptic paddles are used in the dynamic systems course. The paddles were not only useful for displaying virtual environments and feedback control, but the modeling of the various parts of the physical device also provided useful laboratory exercises. Finally, we present qualitative and quantitative evaluations for the haptic paddle and the laboratory exercises.

## 2. Device Description

The haptic paddle is a low-cost, single-axis force-feedback joystick, shown in Figure 2. It is similar in design and function to high-end commercial haptic interfaces such as SensAble Devices’ PHANTOM<sup>8</sup> and Immersion Corporation’s Impulse Engine<sup>7</sup>. All of these interfaces are able to emulate the interaction forces that occur when humans come into contact with physical systems. The primary difference between the haptic paddle and high-end haptic devices is cost. While commercial interfaces can cost several thousands of dollars, the haptic paddle costs less than US \$30.

The mechanical structure of the paddle is composed primarily of laser-cut acrylic. Acrylic parts provide sufficient structural strength while minimizing the material and machining costs. Force is generated by a low-inertia, low-friction, DC servomotor. A gear ratio of 25 to 1 is obtained by a capstan cable transmission. To avoid the cost of expensive digital encoders, position sensing is done with a rare earth magnet and a Hall Effect sensor. Details of the paddle design and a parts list are provided in the Appendix.

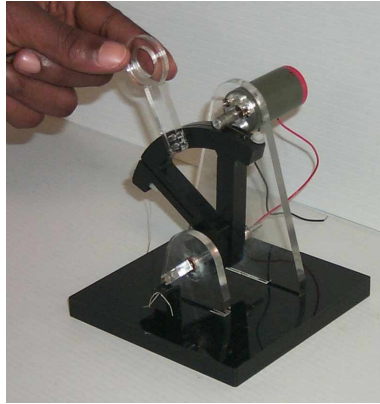

Figure 2. The haptic paddle.

As a user takes the handle of the haptic paddle and moves it from side to side, the position of the handle is sensed. Based upon the position and velocity of the handle, various amounts of force are reflected back to the user. In a course on dynamic systems and control, the haptic paddle is an excellent platform for students to:

- Model a second-order system,
- Estimate the parameters of a system model,
- Observe and analyze the response of a second-order model
- See the effect of pole location on a system's response
- Interact with simulated dynamic systems

Figure 3 below shows how the haptic paddle laboratories corresponded to the various topics in the dynamic systems course.

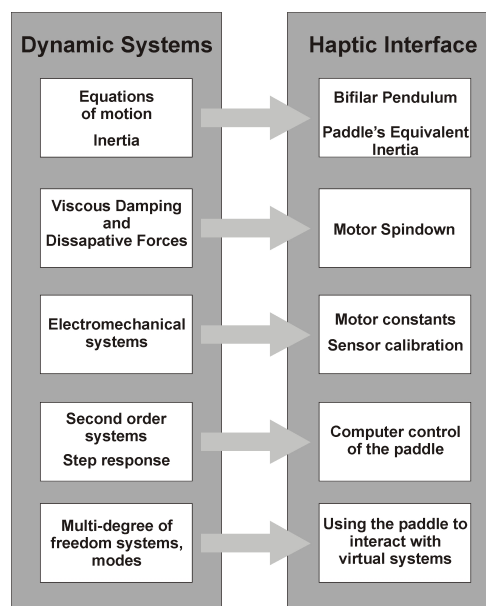

Figure 3. Correspondence between course topics and haptic paddle exercises.

### 3. Modeling and Identification

Early in a course on dynamic systems, students learn to generate the equation of motions governing first and second-order mechanical systems. As part of a laboratory component in a dynamic systems course, the haptic paddle provides a nice example of a typical second-order mechanical system upon which students can experiment. In this section, we describe how students model the behavior of their haptic kit, as well as how they conduct experiments to identify the numerical values of the parameters in the paddle's equation of motion.

#### 3.1 Modeling

The dynamic model of the haptic paddle is very similar to that of the classic inverted pendulum problem often studied in feedback control courses. The handle and sector pulley move as the paddle's motor rotates. As an early objective of the course, students are asked to derive the equation of motion governing the paddle's position. Using either Newton's law or an equivalent method, the equation of motion for the paddle is found to be:

$$(1) (J_s + m_s r_{cg}^2 + N^2 J_m) \ddot{\theta} + (b_s + N^2 b_m) \dot{\theta} - m_s g r_{cg} \sin(\theta) = N(\tau - \tau_f)$$

where

$\theta$  is the angle of the sector pulley measured with respect to a vertical line,  
 $J_s$  is the moment of inertia of the sector pulley about its center of gravity,  
 $m_s$  is the mass of the sector pulley,  
 $r_{cg}$  is the distance from the pulley's center of mass to its center of rotation,  
 $N$  is the paddle's gear ratio (approximately 25),  
 $J_m$  is the inertia of the motor,  
 $b_s$  is the viscous friction in the bronze bushings,  
 $b_m$  is the viscous friction in the motor,  
 $g$  is the acceleration due to gravity,  
 $\tau$  is the torque applied by the motor, and  
 $\tau_f$  is Coulomb friction in the motor.

Equation (1) can be simplified and linearized to give the standard second-order equation:

$$(2) J_{eq} \ddot{\theta} + b_{eq} \dot{\theta} + k_{eq} \theta = T$$

Like the typical mechanical second-order system model, our model of the haptic paddle contains an inertial component  $J_{eq} \ddot{\theta}$ , a component representing the energy dissipation in the system,  $b_{eq} \dot{\theta}$ , a component corresponding to the potential energy stored in the system,  $k_{eq} \theta$ , and a forcing function  $T$ .

$$(3) J_{eq} = (J_s + m_s r_{cg}^2 + N^2 J_m)$$

$$(4) b_{eq} = b_s + N^2 b_s$$

$$(5) k_{eq} = -m_s g r_{cg}$$

$$(6) T = N(\tau - \tau_f)$$

Because  $k_{eq}$  is negative, the haptic paddle is an unstable system in the absence of feedback control.

### 3.2 Identification

After students have learned to model the motion of a paddle with Equation (2), they use their actual paddle components to obtain numerical values for the parameters in the equation. Details of how the paddle is used to teach students to identify model parameters are illustrated in Figure 3 and in the sections below.

#### 3.2.1 Inertial Components

To determine the paddle equivalent inertia, students must experimentally measure the moment of inertia of the paddle's sector pulley. The mass of the sector pulley,  $m_s$ , is easily obtained by weighing it. Similarly, the gear ratio,  $N$ , can be calculated by direct measurements of the motor pulley and sector pulley radii. Students obtained the motor's rotor inertia using the motor manufacturer's catalog.

To obtain an estimate of the sector pulley's inertia, students used the bifilar pendulum method as illustrated in Figure 4<sup>11</sup>. By experimentally measuring the frequency of oscillation of the paddle sector pulley, an estimate of its inertia is readily calculated. Students estimate  $r_{cg}$ , the distance to the paddle's center of mass, by balancing the paddle on a knife edge.

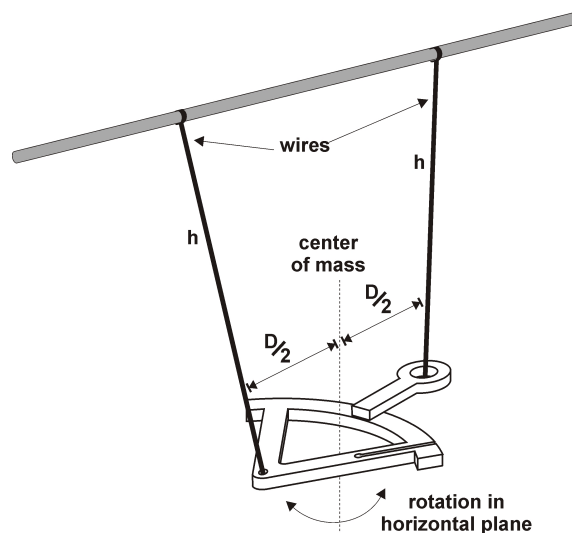

Figure 4. Using the bifilar pendulum method to measure moment of inertia.

With values for  $J_s$ ,  $m_s$ ,  $r_{cg}$ ,  $N$  and  $J_m$ , the students calculate the system's equivalent inertia  $J_{eq}$ . By playing with their assembled kits, students can readily confirm that the motor inertia, while only

about 1/70 the inertia of the sector pulley, dominates the equivalent inertia because it is multiplied by the square of the gear ratio,  $N$ .

### 3.2.2 Dissipative Components

The DC motors in the haptic paddles are an ideal means to teach students about the response of a first-order system, and how to estimate a system's equivalent damping coefficient,  $b_{eq}$ . Students begin by measuring the motor's angular velocity,  $\omega$ , as it spins with no applied torque.

$$(7) \quad J_m \dot{\omega} + b_m \omega = -\tau_f$$

Students solve this equation, and find that if the motor begins with an initial angular velocity,  $\omega_o$ , its velocity as a function of time is

$$(8) \quad \omega(t) = e^{-\frac{b_m t}{J_m}} \left( \omega_o + \frac{\tau_f}{b_m} \right) - \frac{\tau_f}{b_m}$$

If the Coulomb friction torque in the motor is negligible then Equation (8) becomes

$$(9) \quad \omega(t) = \omega_o e^{-\frac{b_m t}{J_m}}$$

To estimate  $b_m$ , students experimentally record the velocity of their motor as it spins down from an initial velocity. Using Equation (9) and the known value of  $J_m$ , students are able to identify the viscous damping coefficient of their motor. Assuming that  $b_s$ , the viscous and Coulomb friction in the bronze bushings, is negligible, the equivalent damping coefficient,  $b_{eq}$ , is calculated as

$$b_{eq} = N^2 b_m .$$

### 3.2.3 Potential Energy Components

As mentioned previously, the haptic paddle's equation of motion is similar to that of an inverted pendulum. The students observe this unstable behavior in the lab (the paddle's handle will fall to one side if it is disturbed from its vertical equilibrium position). Gravity is the only source of potential energy in the haptic paddle. In later laboratory exercises where students experiment with feedback control, they learn how to compensate for this instability by adding proportional feedback.

### 3.2.4 Forcing Function

During the segment of the course when students learn about electrical and electromechanical systems, the motor of the haptic kit again provides an ideal set of laboratory exercises. Students measure the torque and speed constants of their motors and estimate the maximum force (approximately 7.5 N) that the paddle can generate at the handle. The torque and speed constants are measured using a variable voltage power supply, ammeter, encoder, and a set of small weights ranging from 10g to 200g. To obtain the torque constant, students suspend various

weights from the motor's pulley and measure the current required by the motor to make the weight appear to be "neutrally buoyant." To obtain the motor voltage/speed constant, the motor is spun at a known shaft velocity. This is accomplished by connecting the students' motor to a second motor that is equipped with a digital encoder. As the motor spins, the voltage it generates is measured. Then the speed constant can be determined from the slope of a speed versus voltage plot.

### 3.2.5 State Measurement/Estimation

While learning about electrical and electromechanical systems, students also use the position sensor from their haptic paddle learn about measuring the state of a dynamic system. Students calibrate the sensor by measuring the output voltage of the sensor as a function of the paddle's angle. The sensor is mounted on the base and responds to changes in the magnetic field of a small cylindrical magnet mounted at the pivot point. The output is nearly linear for small motion, but noticeably sigmoidal over the full +/- 35° range of motion. The sensors are therefore calibrated using a best-fit cubic.

## 4. System Response and Feedback Control

Until now, we have focused primarily on the modeling and identification of the various components of the haptic paddle. However, connecting the device to a computer and using feedback control shows that the haptic paddle is much more than the sum of its parts.

### 4.1 Second Order Systems

An important part of any course in dynamic systems is the response of second-order systems. The final equation of motion for the haptic paddle without feedback control was shown in Equation (2).

By now, all the parameters have been identified. There are several things that the students can learn by examining this equation. First, one can determine the poles of the system as shown in any dynamic systems book<sup>3</sup>. Since one of the poles has a positive real part, the system is not stable. This is because of the paddle's center of gravity is above its center of rotation. If the haptic paddle handle is pointed directly upwards, the paddle will stay in this equilibrium position. However, any disturbance from equilibrium will cause the handle to fall over.

### 4.2 Effects of Feedback Control

We have seen in the previous section that the haptic paddle is inherently unstable. However, the addition of proportional-derivative feedback control can make the system stable. This feedback torque can be described by:

$$(10) \quad T = K_p \theta + K_v \dot{\theta}$$

When combined with the original system, the new equation of motion is:



$$(11) \quad J_{eq} \ddot{\theta} + (b_{eq} - K_v) \dot{\theta} + (k_{eq} - K_p) \theta = 0$$

With feedback control, the students may calculate the equivalent poles and determine the values of the feedback parameter  $K_p$  and  $K_v$  to satisfy the requirements for stability.

Now we start the exciting part: the haptic paddle, with the necessary amplifier circuit, is connected to the computer. Control software was designed that allows students to change the values of the feedback parameters  $K_p$  and  $K_v$  while the haptic paddle is being controlled. The results of changing the parameters may be observed by feeling (holding the paddle handle and moving it around), as well as by vision (deflecting the paddle and releasing it, and watching how it responds based on the initial conditions). One can also add a step input and observe the response. Several devices may be controlled at once, allowing groups to compare different control laws on adjacent haptic paddles. A detailed description of how feeling the haptic paddle was used to enhance learning is presented in Section 5.

### 4.3 Interpretations of System Response

The haptic paddle control software can also be configured to take several seconds of position, velocity, and input force data. Students were asked to tune the feedback gains to make the haptic paddle respond to a step input or initial condition (giving the homogeneous response) like a classic, lightly damped second-order system. From position data taken during the response, students were asked to determine the corresponding dimensionless damping parameter,  $\zeta$ , and damped natural frequency,  $\omega_d$ . An ideal second-order system response (using Equation (12) below) was then plotted over the actual haptic paddle data.

$$(12) \quad \ddot{x} + 2\zeta\omega_n\dot{x} + \omega_n^2x = 0$$

The students observed that the plots of actual data did not precisely match those of an ideal second-order system due to the presence of Coulomb friction. An example of a typical plot is shown in Figure 5.

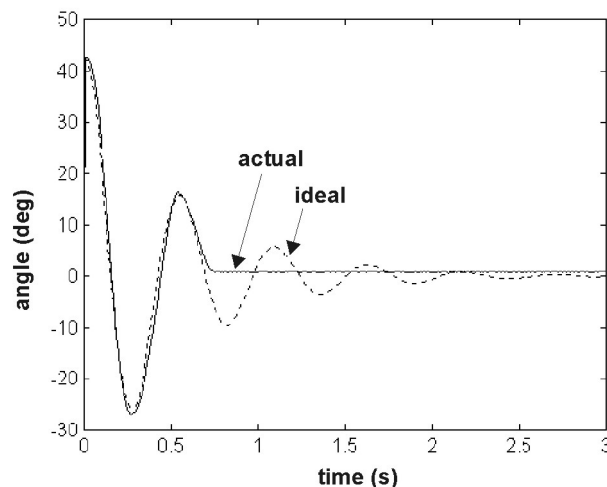

Figure 5. Homogeneous response of the haptic paddle with proportional-derivative feedback control versus an ideal second-order system

## 5. Feeling is Believing

Perhaps the greatest advantage of using a haptic paddle to teach dynamics systems is the fact that the paddle can be used to simulate an unlimited number of “virtual systems.” Several virtual environments were designed and simulated. During this final stage of the course, students are able to make their haptic paddle behave as if it were a virtual spring, or as if it were a virtual dashpot. By adjusting the magnitude of the virtual spring constant ( $K_p$ ) or the virtual damping constant ( $K_v$ ), students could immediately feel the effects of greater stiffness and greater damping. Moreover, by experimenting with negative values for the spring and damping constants students gained an immediate intuition of how such values make a system unstable. In short, the paddles allow students to interact with physical systems that do not even exist.

As a final demonstration of the haptic devices, two virtual environments were designed in which four haptic devices could be used simultaneously. In the first virtual environment, called “haptic tetherball,” four students using haptic devices cooperated to make a virtual inverted pendulum with a small amount of Coulomb friction stand upright (Figure 6a). Force feedback, and a simple visual representation, allowed students to sense when the ball hit their paddles and to feel the force it took to bat the ball back towards the apex. If a student hit the ball too gently, it fell back against her paddle, if she hit it too hard it continued past the apex to land on the paddle of the player on the opposite side.

The second environment, “excite the modal frequencies” (Figure 6b), used a virtual model of a two degree-of-freedom system. To impart forces from the system to the finger, each haptic device was virtually attached to a mass  $M_2$  through a stiff spring. (The spring was chosen to be sufficiently stiffer than the springs in the virtual system that it did not noticeably affect the perceived dynamics.) This attachment allowed the students to directly manipulate the virtual system and feel the inertia of both masses. The goal was to move the haptic device such that only one of the two modal frequencies of the system was excited. This virtual environment also gave students the opportunity to see and feel the concepts of eigenvalues and eigenvectors. In this example, eigenvalues correspond to the modal frequencies and the eigenvectors to the relative directions of the two masses in the system.

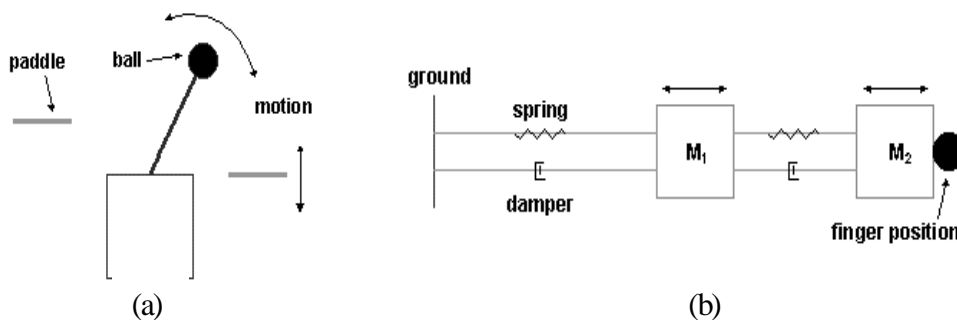

Figure 6. (a) Haptic tetherball. (b) Excite the modal frequencies.

## 6. Discussion and Conclusions

In this section, we examine the effectiveness of the haptic paddle as a learning tool. We present information obtained from both formal and informal surveys of the students, as well as address issues of importance to the instructors of the course.

### 6.1 Student Assessment

To objectively determine the degree to which learning and understanding of dynamic systems have been affected by using the haptic paddles, we would have to compare the performance of groups of students in the same class with and without the addition of haptic paddle laboratories and demonstrations. As this is impractical and unfair in an educational setting, we instead surveyed the students about their perceived value of the labs and their opinions on the haptic paddle.

While it is difficult to quantify the pedagogical effectiveness of using the haptic paddles, the qualitative impact was quite positive. The students responded enthusiastically to having their own examples of high-performance electromechanical systems. Many students personalized their designs and even made design modifications to improve performance. Once the kits were assembled and connected to the computer, many students who had already heard about resonant frequencies, feedback, stability, etc. in the lectures were clearly surprised at how small changes in the feedback gains could have a profound effect on system behavior. It was also evident while watching the students compare their actual versus ideal step responses and estimate dimensionless damping and frequencies, that many of the students were fully understanding these concepts for the first time.

The feedback on end-quarter course surveys was generally positive. Table 1 below shows the results from questions relating to the haptic paddle. All the labs in the course except two (shaded) involved haptics.

Lab	Title	Mean Rating	Max Rating	Min Rating
1	Motor spin down test	3.0	5	1
2	Bifilar pendulum	2.9	5	1
3	Equivalent inertia	3.2	5	1
4	Harmonic forcing	3.5	5	2
5	Motor constants/sensor calibration	3.1	5	1
6	Speakers	3.9	5	1
7	Feedback control	4.3	5	3
8	Fun with control	4.4	5	3

Table 1. Haptic paddle survey results. The ratings range from 1 to 5, given to the students as “1=yuck, 3=okay 5=awesome!”. (Data from an instructor-generated course survey, Mechanical Engineering 161, Stanford University, Fall 1998.)

Students were also asked for comments about the labs and the haptic paddle in particular. We received both positive and negative comments, some with constructive criticism. Some of the positive comments are listed below:

“I think they were good because we learned what we needed, and didn’t spend a great deal of time doing it.”

“All great overall, there just not all awesome.”

“Very high-tech!”

“Useful and overall ... time well spent.”

“One of the better labs I’ve done because each on built on the previous one and it supported the course material well. Very helpful.”

“Keep em up. They helped out a lot.”

As expected, there were also criticisms:

“There was a disparity in the amount of times the labs took, with the first few labs being extremely short and the last few taking much longer.”

“The labs somehow seemed extraneous to the class. It would be nice to hear more references to the lab in lecture...”

“Short ones were good. Long ones were bad.”

## 6.2 Feedback from Instructors

As the instructors for the class are the same as the authors of this paper, we can comment on the effect of using the haptic paddles on the teaching team. To begin, designing and constructing new laboratory equipment is always challenging and time consuming. Developing the haptic paddle kits was especially demanding in that the kits had to be simple and robust enough for students to assemble without direct supervision. The first quarter the haptic paddles were used, the design, construction and software development all took place throughout the course, which led to some students feeling frustrated when things did not run smoothly. In subsequent quarters, the load on the teaching staff was less, although constant refinements to the design, software, and lab instructions still made using the haptic paddles a significant amount of extra work.

So, as instructors, why do we place this burden on ourselves? Seeing how the haptic paddles helped students grasp concepts that had been inaccessible before was an unquestionable reward. There are also other rewards resulting from combining research with teaching. The authors’ research is in haptics; this was not only a new application of our studies, but also a chance to get undergraduates excited about our work.

## 6.3 The Future of the Haptic Paddle

This work was first presented at the Haptic Symposium of ASME’s Dynamic Systems and Control Division, generating interest among other haptics researchers in using haptic paddles in

their classrooms and laboratories <sup>10</sup>. We offered sample haptic paddle kits (only the paddle hardware, not including the amplifier) at cost to several individuals in the haptics community. The response was very positive; we distributed over 20 kits to researchers at eight universities in three countries. At least one professor is designing his own haptic device for use in an undergraduate course. Although we no longer have the parts to continue distributing extra kits, all the information needed to create a kit is available from our website at <http://cdr.stanford.edu/touch/paddle>. The web page also contains links to DXF files for the laser-cut parts, source code for the control software, and detailed assembly instructions with pictures.

Will the haptic paddle continue to be used at Stanford? To some degree, this depends on which instructors teach the dynamic systems course. In the last four quarters that the dynamic systems course has been offered, the haptic paddles were used three times. When the instructor and/or teaching assistant(s) are unfamiliar with haptic technology, or are not as inclined to give laboratory assignments and demonstrations, it is less likely that the paddles will be used. However, it is our hope that by standardizing the paddles and labs, the devices will be used even when the teaching staff is not composed of haptics researchers.

### Acknowledgments

This work was partly supported by ONR URI #N00014-92-J-1997, a National Science Foundation Fellowship, and the Stanford University Department of Mechanical Engineering. Special thanks are due to the research and teaching assistants who have worked on this project: Christopher Edmonds, Weston Griffin, Jesse Drogusker, Bart Nielsen, and David Siu. The authors also gratefully acknowledge the assistance of Drs. Paul Mitiguy, Ken Sasaki, and Edward Carryer. Jorge Cham provided Figure 1. Finally, we express our appreciation to the students of ME161 at Stanford for both their patience and enthusiasm.

### Bibliography

1. Bonert, R. (1989). Interactive simulation of dynamic systems on a personal computer to support teaching. *IEEE Transactions on Power Systems*.
2. Burdea, G. (1996). *Force and touch feedback for virtual reality*. New York: John Wiley & Sons.
3. Close, C. M., & Frederick, D. K. (1993). *Modeling and analysis of dynamic systems* (2nd ed.). Boston: Houghton Mifflin.
4. Conley, E., & Kokjer, K. (1989). Classroom computers: don't forget the analog. *CoED (Journal) (Computers in Education Division of ASEE)*.
5. Costa, M. A., Okamura, A. M., Richard, C., & Zinn, M. (1995). *HRoach: A 3D Haptic Video Game with Interactive Dynamics*. Stanford, CA: CS225 Final Project - Stanford University.
6. Dawson, S. L., & Kaufman, J. A. (1998). Imperative for medical simulation. *Ieee*, 86(3), 479-483.
7. URL: <http://immerse.com>; Immersion Inc.
8. URL: <http://sensable.com>; SensAble Devices Inc.

9. Lee, K.-M., Daley, W., & McKlin, T. (1998). *Interactive learning tool for dynamic systems and control*. Paper presented at the 1998 ASME International Mechanical Engineering Congress and Exposition, Anaheim, CA, USA.
10. Richard, C., Okamura, A. M., & Cutkosky, M. R. (1997). *Getting a feel for dynamics: Using haptic interface kits for teaching dynamics and controls*. Paper presented at the 1997 ASME International Mechanical Engineering Congress and Exposition, Dallas, TX, USA.
11. Steidel, R. F. (1989). *An introduction to mechanical vibrations* (3rd ed.). New York: Wiley.

#### Appendix: Design and Construction Notes

The major components of the kits were constructed of ¼ inch thick acrylic plastic (see Figure 7). We sent our acrylic sheets along with DXF files of the part geometries to a local laser-cutting firm, resulting in a per-kit cost of approximately \$8.00. Although acrylic has lower strength and stiffness than aluminum or steel, it is adequate for the loads encountered in the single-axis joysticks, provided that stress concentrations are avoided. Acrylic has the advantage of being easy to glue and laser cut. Laser cutting provides an inexpensive way to obtain complex planar geometries with dimensional tolerances to 0.005 inch. The laser-cut features also have a smooth finish, which helps to reduce stress fractures.

A side effect of the laser-cutting process is that all holes have a slight taper. After some experimentation we found the right nominal hole diameter such that Teflon bushings could easily be pressed in from one direction to obtain a snug fit with the 1/8 inch diameter steel shafts.

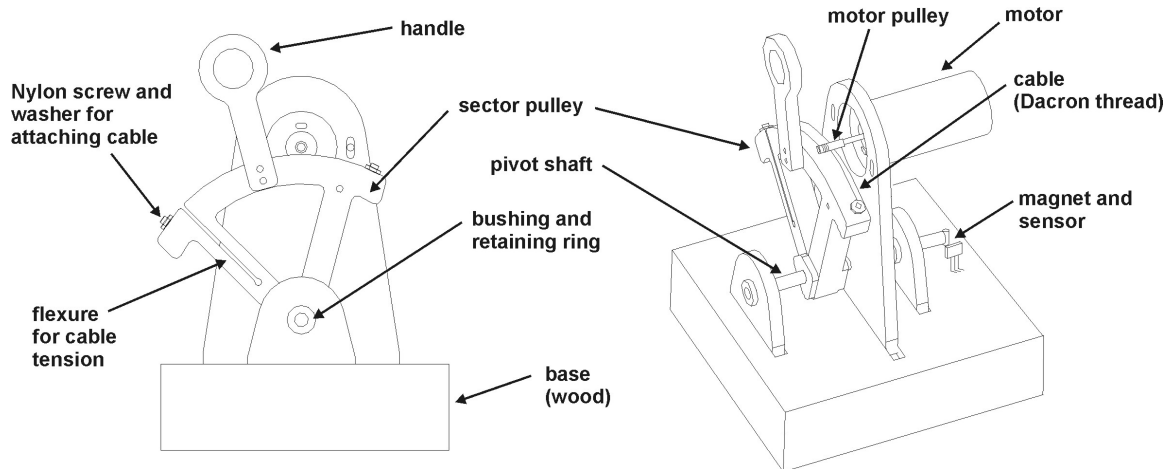

Figure 7. Components of the haptic paddle kit.

The actuators for our system are low-inertia, low-friction DC servomotors, similar to those used in commercial haptic devices but smaller and less powerful. They were obtained from various San Francisco-area surplus electronics stores at an average cost of \$9.00. Similar motors are often available from mail-order surplus electronics houses such as C&H Sales, Pasadena, CA and Servo Systems Co., Montville, NJ.

The motors are powered by small current amplifiers constructed from LM675 power operational amplifiers, which were donated by the manufacturer. The circuit diagram is shown in Figure 8. With a power supply of 12 volts and D/A output of  $\pm 5$  V, the amplifiers generated a maximum current of 1.5 amps, resulting in a maximum motor torque of 0.035 Nm and a maximum force of 7.5 N at the joystick handle. . (The amplifiers are capable of 3.0 amps with higher signal voltages.)

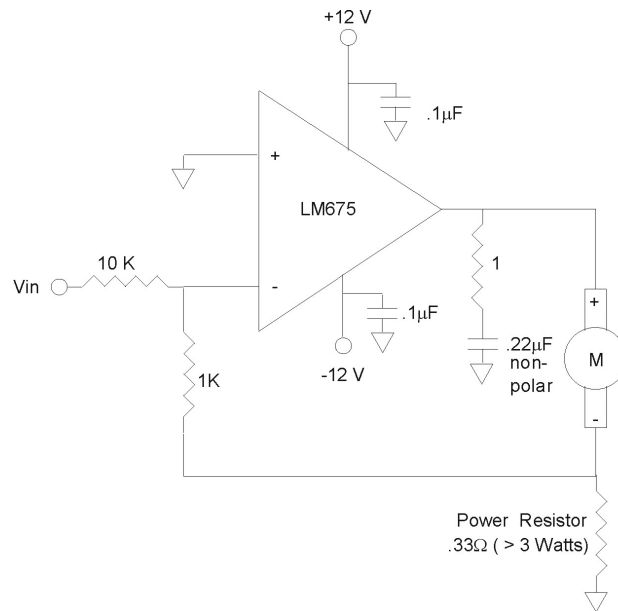

Figure 8. Circuit diagram for current amplifiers.

A cable, pinned at both ends of the sector pulley and wrapped several times around the motor pulley, provides a smooth “cogless” transmission. The cable represents a compromise between cost, strength and resistance to creep. We ultimately chose SpiderWire, a type of fishing line, and designed an elastic flexure into the sector pulleys (see Figure 7) to minimize problems associated with cable stretch. Because the flexure is always under preload, it does not affect the system dynamics. The ends of the cables are fastened with nylon screws and washers to avoid damaging the thread and acrylic. The position of the sector pulley was sensed using a Hall effect sensor and a small cylindrical magnet glued at the pivot. This strategy avoided the cost of an encoder for each kit and allowed us to use existing analog input hardware in the laboratory. As mentioned earlier, the output of the sensor varied linearly with small angles, but fell off near the ends of the  $\pm 35$  degree range of motion. It was therefore necessary for the students to calibrate the sensors using a cubic polynomial.

#### CHRISTOPHER RICHARD

Christopher Richard is currently a doctoral student at Stanford University. He received his B.S. in Mechanical Engineering from the University of California at Davis and his M.S. in Mechanical Engineering from Stanford University. His advisor is Dr. Mark Cutkosky and his research involves modeling and haptic display of physical properties such as friction and inertia. He has taught a class in Dynamic Systems, and coordinates workshops and seminars on effective research strategies and issues of diversity among engineering students and faculty.

#### ALLISON M. OKAMURA

Allison Okamura is currently a doctoral student at Stanford University. She received her B.S. in Mechanical Engineering from the University of California at Berkeley and her M.S. in Mechanical Engineering from Stanford University. Her advisor is Dr. Mark Cutkosky and her research areas are dexterous manipulation and exploration with robotic fingers, and enhancing virtual environments with vibration feedback. She has taught classes in Dynamic Systems and Engineering Graphics and Communications, and is active in a Mechanical Engineering women’s group that strives to increase communication between graduate women across disciplines.

#### MARK R. CUTKOSKY

Mark R. Cutkosky joined the Design Division of the Stanford Mechanical Engineering Dept. in 1985, after working for several years in the Robotics Institute at Carnegie-Mellon University and as a machine design engineer at ALCOA, in Pittsburgh, Pennsylvania. He is a principal investigator of the Design Space Colonization project at the Center for Design research, director of the Dexterous Manipulation Lab, and co-director of SIMA, the Stanford Integrated Manufacturing Association.